

# TD1855 Calibrator for Multimeter

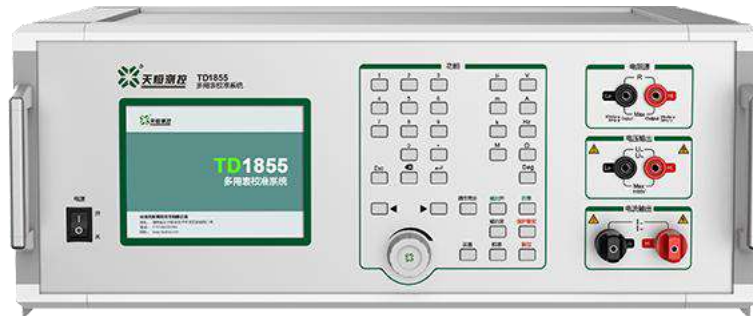

## 1. Summary

TD1855 multimeter calibration system is a multifunctional calibrator, which integrates the functions of AC/DC voltage standard source, current standard source, resistance standard source, etc. It has AC/DC power and pulse frequency output functions, and the accuracy class is 0.05. It can cover the calibration of 3.5 digital/analog multimeters or single-function voltmeters, ammeters, ohmmeters, and power meters, and has a very high cost performance.

## 2. Features

- DC voltage output: 20 mV ~ 1100 V
- DC current output: 2  $\mu$ A ~ 22 A (33 A is optional)
- AC voltage output: 20 mV ~ 1100 V
- AC current output: 200  $\mu$ A ~ 22 A (33 A is optional)
- Sinusoidal wave frequency: 45 Hz ~ 1100 Hz
- Simulated DC resistance: 10  $\Omega$  ~ 220 M $\Omega$ , continuously adjustable
- 2 MHz square wave frequency output
- Phase output
- AC/DC power output
- Multiple value output modes
- Remote adjustment (optional)
- Clamp meter calibration (optional)
- Transducer calibration(optional)

### 3. Application

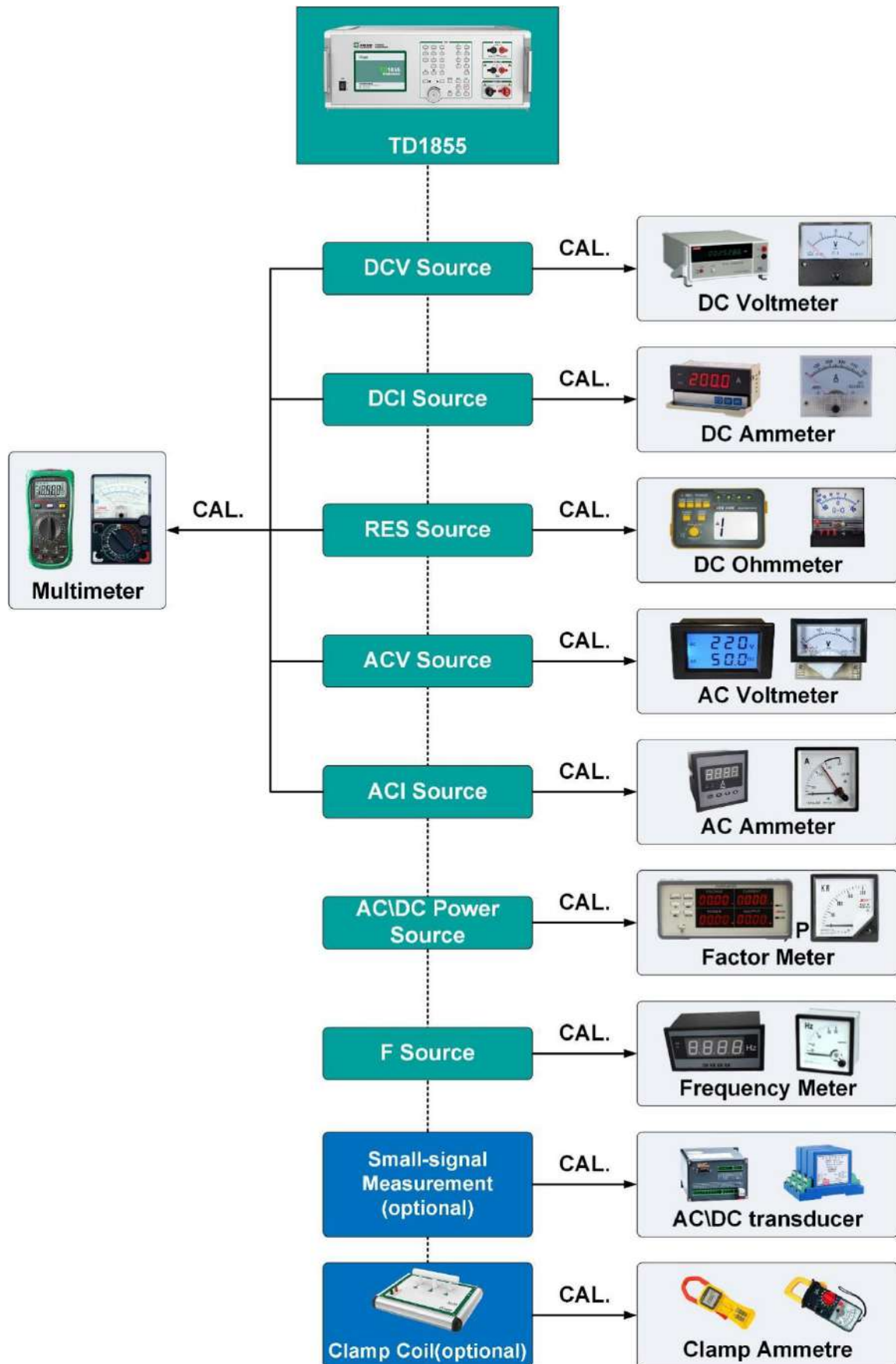

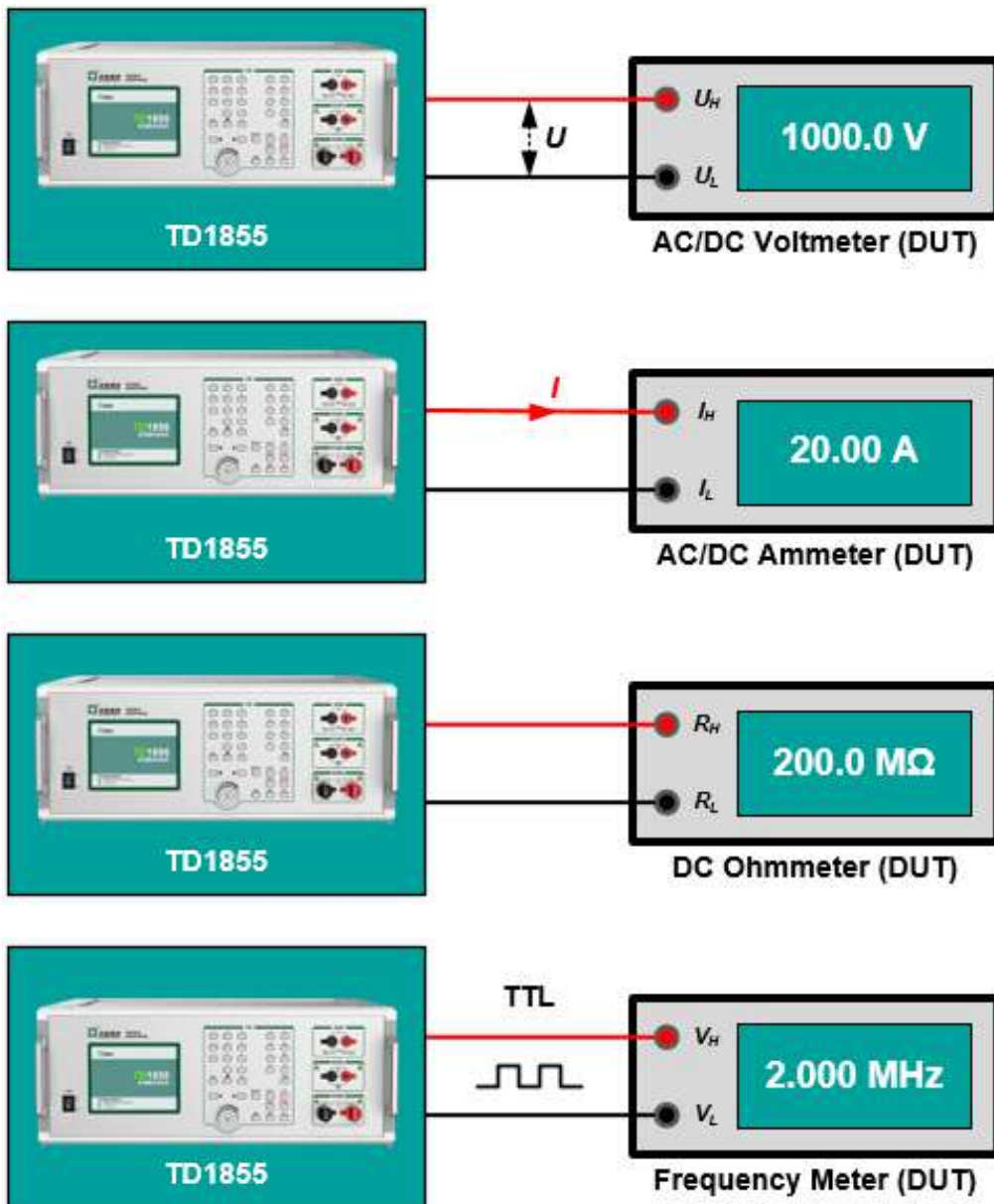
**☆ Calibrate AC/DC electrical measuring instruments**

- **DCV output:** 20 mV ~ 1100 V
- **DCI output:** 2  $\mu$ A ~ 22 A or 33 A
- **ACV output:** 20 mV ~ 1100 V, 45 Hz ~ 1100 Hz
- **ACI output:** 200  $\mu$ A ~ 22 A or 33 A, 45 Hz ~ 1100 Hz
- **RES output:** 10  $\Omega$  ~ 220 M $\Omega$
- **Frequency output:** 1 Hz ~ 2 MHz
- Suitable for calibrating three-and-a-half-digital multimeters, AC and DC voltmeters, AC and DC ammeters, resistance meters of class 0.2 and below, and frequency meters of class 0.01 and below.

☆ Calibrate AC\DC power meters

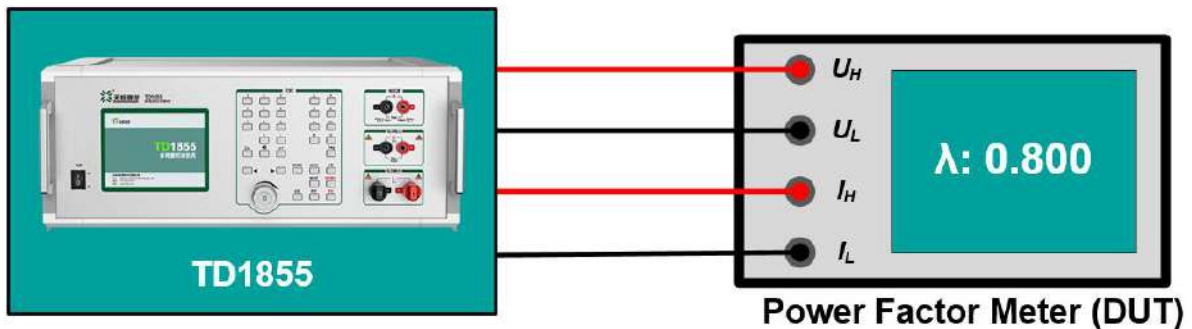
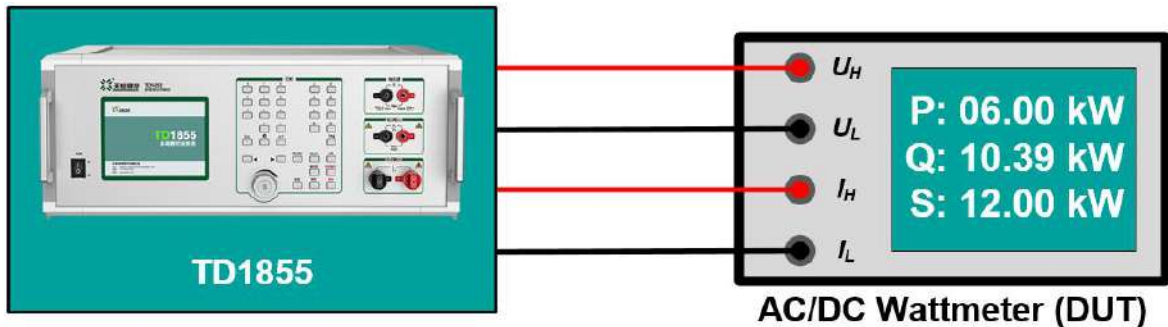

- Application scenario: The virtual power standard source composed of independent outputs of AC/DC voltage (DCV/ACV) and AC/DC current (DCI/ACI) with adjustable phase is suitable for calibrating AC/DC power meters.
- Suitable for calibrating DC power meters of class 0.5 and below, active power meters, reactive power meters, apparent power meters, power frequency phase meters and power factor meters.

☆ Calibrate clamp ammeter (optional)

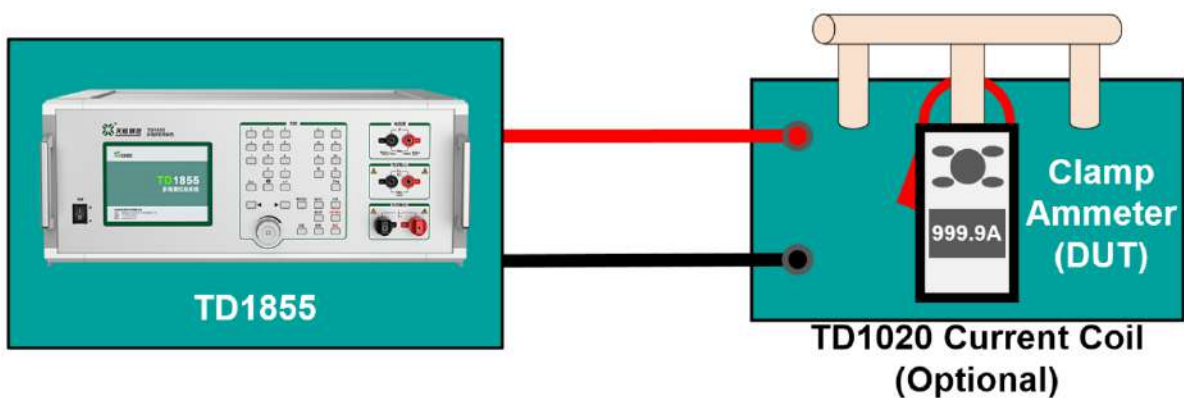

- Users can choose TD1020 current coil (50 turns), pass 20 A AC and DC standard current,

and achieve equivalent current output of up to 1000 At, which is suitable for calibrating clamp ammeters or current clamps with lower accuracy class 1 and below.

- If you need to calibrate a clamp ammeter with higher accuracy, you can choose Tunkia TD1050 clamp ammeter calibration device product.

☆ Calibrate AC/DC Transducer (optional)

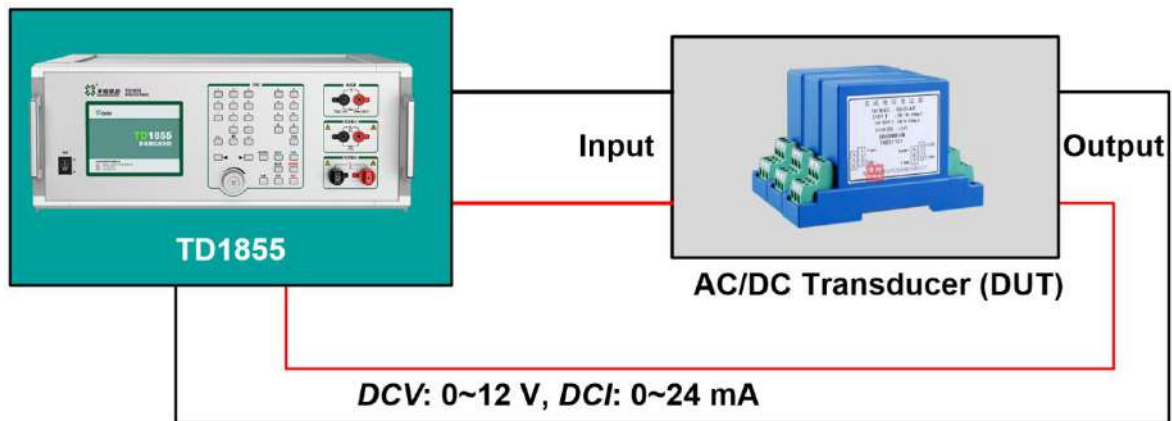

- Optional DC small signal measurement function, supporting maximum DC 12 V or 24 mA signal input.
- Combined with the multi-function standard source output function, it can detect the proportional error of AC and DC voltage/current transmitters.

4. Panel Features

☆ Front\Side Panel

**Figure(a) Front Panel**

**Figure(b) Side Panel**

S/N	Description
<span style="font-size: 1.2em; color: white;">1</span>	<b>LCD touch screen:</b> intuitive display of multiple power levels and touch operation greatly improves the usability of the instrument.
<span style="font-size: 1.2em; color: white;">2</span>	<b>Key operation panel:</b> multiple value input and adjustment modes greatly improve the convenience of instrument operation.
<span style="font-size: 1.2em; color: white;">3</span>	<b>DC analog resistance output terminal:</b> two-wire connection mode.
<span style="font-size: 1.2em; color: white;">4</span>	<b>AC and DC voltage output terminal:</b> adopts protective terminal to prevent high voltage danger caused by misoperation.
<span style="font-size: 1.2em; color: white;">5</span>	<b>AC and DC current output terminal:</b> can be connected to $\Phi 4$ safety banana or U-shaped plug, and supports a maximum current of 22 A or 33 A.

<b>6</b>	<b>Handle:</b> The front panel is equipped with a pair of handles to facilitate users to move or carry the instrument.
<b>7</b>	<b>DC transmitter secondary signal input terminal:</b> supports the input of a maximum DC 24 mA or 12 V signal.

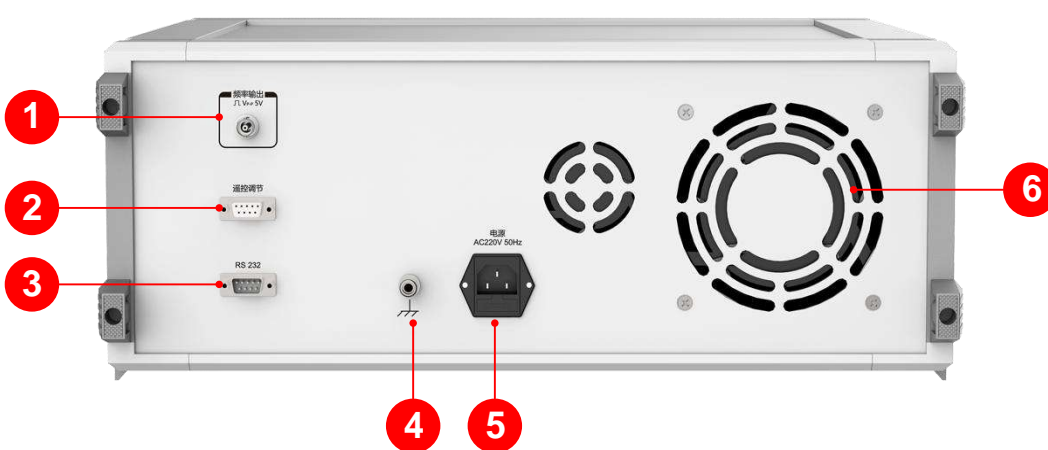
☆ Rear Panel	
	
S/N	Description
<b>1</b>	<b>Pulse frequency output terminal:</b> BNC female.
<b>2</b>	<b>Remote control box interface:</b> Connect the remote control box (optional) via a control cable.
<b>3</b>	<b>RS232 communication interface:</b> Can be connected to a computer to facilitate user programming and control of the output of the multi-function standard source.
<b>4</b>	<b>Case ground interface:</b> The instrument should be grounded before operation to ensure power safety.
<b>5</b>	<b>Power interface:</b> AC 220V power input interface with fuse.
<b>6</b>	<b>Instrument heat dissipation port:</b> Heat is dissipated through the built-in radiator and fan to ensure the stability of the internal temperature of the instrument and improve measurement accuracy.

## 5. Characteristics

### ☆ Wide output range

	1 $\mu$	1m	1	1k	1M	1G
<b>DCV</b>	20 mV  1100 V					
<b>DCI</b>	2 $\mu$ A  22 A / 33 A					
<b>RES</b>	1 $\Omega$ 220 M $\Omega$					
<b>ACV</b>	20 mV  1100 V					
<b>ACI</b>	200 $\mu$ A  22 A / 33 A					
<b>F<sub>~</sub></b>	45 Hz  1100 Hz					
<b>F<sub>~</sub></b>	1 Hz  2 MHz					
<b>P<sub>U-I</sub></b>	3 V $\times$ 0.2 mA  600 V $\times$ ( 22 A / 33 A )					

- **Solution value:** The multifunctional standard source output range of TD1855 covers the working range of electrical measuring instruments such as three-and-a-half-digit multimeters, and can be calibrated directly using the standard source method.

### ☆ High load capacity

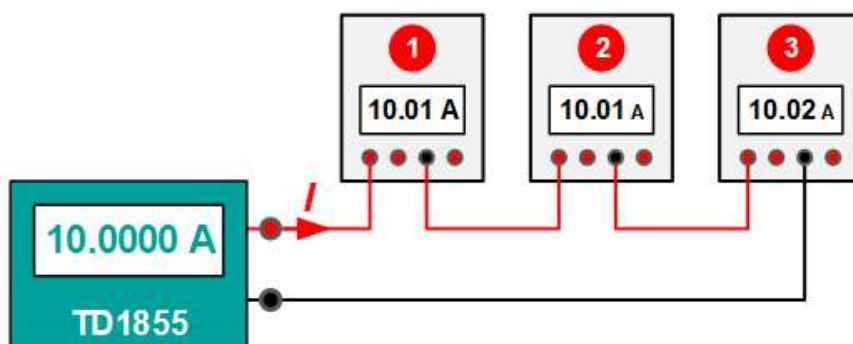

Figure(a) Supports simultaneous calibration of multiple digital meters



Figure (b) Pointer-type analog meter

- The voltage and current standard sources of TD1855 have strong driving capabilities, ensuring that the instrument can still maintain high-precision and high-stability constant voltage or constant current output when connected to a large load, and can cover the

calibration of analog pointer instruments.

- The strong output load capacity can also realize the simultaneous calibration of multiple digital AC and DC instruments.

(Note: The specific number is related to the load size of the meter being tested)

## ★ Easy to operate

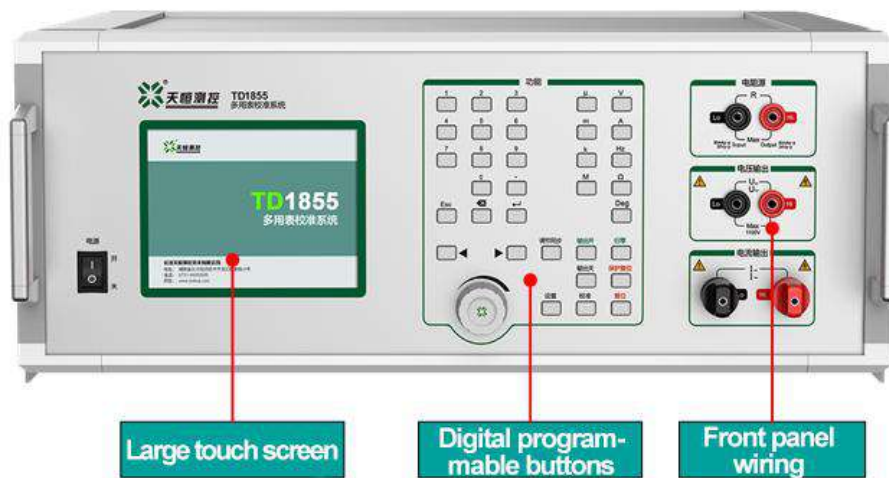

- **Large-size touch screen:** full color, high screen brightness, clear picture quality, support touch operation, comprehensive functions, simple and fast.
- **Digital programmable buttons:** can realize multiple input methods such as fixed-point output, rotary encoder, and step adjustment, and the operation is convenient and fast.
- **Front panel wiring:** convenient for users to replace current and voltage test wires when checking the meter.
- **Solution value:** This combined operation method effectively improves the convenience of operation to adapt to a variety of application scenarios.

★ Multiple output\adjustment methods

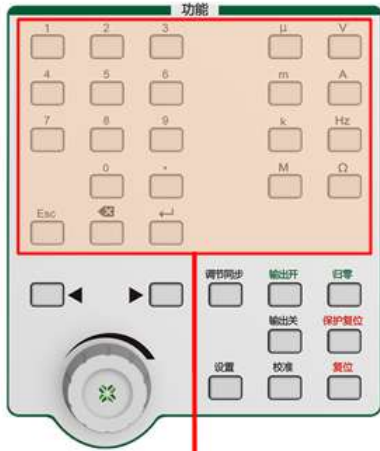

Figure (a) Digital buttons on the operation panel

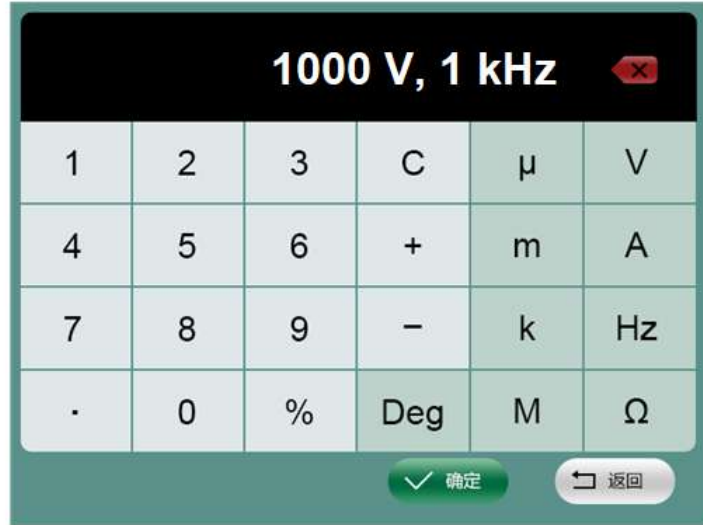
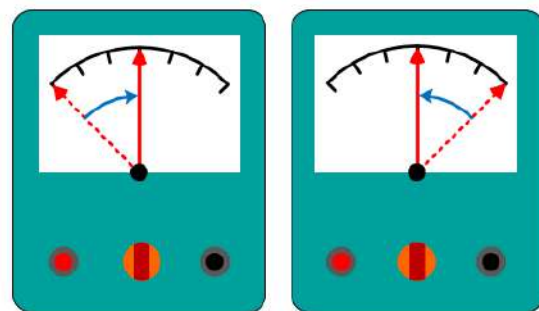
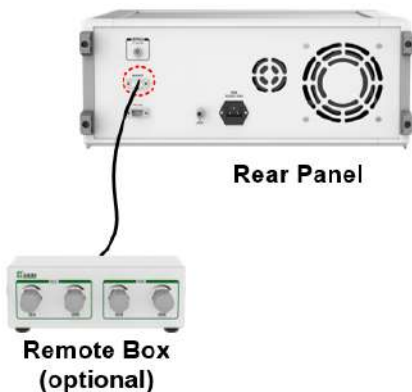

Figure (b) Touch screen value output interface

- The instrument has a "fixed-point output" mode. You can directly set the required output value by pressing the digital buttons on the console or clicking the touch screen. The instrument will automatically switch to the optimal range output, making it very convenient to calibrate digital instruments.
- Especially when setting the AC voltage/current output, you can directly enter the amplitude and frequency at the same time (as shown in Figure(b) above), which is very convenient to use.



Convenient to calibrate "differences between rising and falling"

- The calibration of analog pointer type usually needs to be carried out scale by scale, especially the "rising and falling variation" (the change caused by the rise and fall of the inspected point), and the output of the source needs to be adjusted to align the indicator of

the inspected table to the graduation line of the inspected point.

- It is relatively inconvenient to use the digital fixed-point output method to adjust the output of the standard source to achieve scale alignment.
- For this reason, we provide users with a **remote box (optional accessory)**. Through the operation of coarse adjustment-fine adjustment, the output can be quickly adjusted to align with the scale of the inspected table, which is very convenient to complete the calibration of the analog table. This function is particularly useful when it is necessary to consider the friction or hysteresis effect during movement.



Instrumentos de Medida, SL  
<https://idm-instrumentos.es>

Septiembre 31  
T. 34 91 300 0191

### ★ Multiple output\adjustment methods

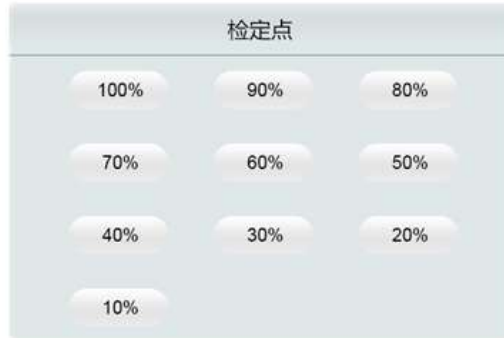

Touch screen "percentage" calibration point interface



**Full scale output**



**90% scale output**

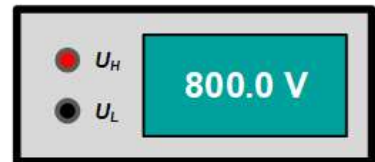

**80% scale output**

- When calibrating electrical measuring instruments, it is usually necessary to select calibration points according to the proportion of each range of the meter being tested.
- Users can easily select the calibration points of the meter being tested through the percentage "calibration point" function on the touch screen of this instrument.

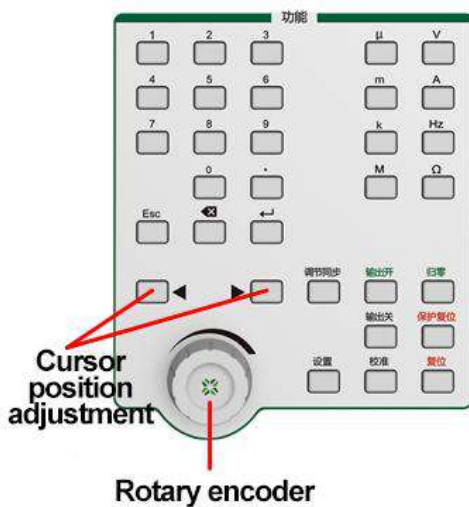

- **"Rotary Knob"** mode, User can set in clockwise direction or anticlockwise direction. Then rotate clockwise or counterclockwise to increase or decrease the output value.

## 6. Specifications

### 6.1 DC Voltage/Current Output

Range	Resolution	Stability (%/min)	Uncertainty (k=2) (ppm*RD+ppm*RG) <sup>[1]</sup>	Max burden (mA)	Ripple Factor(%)
200 mV	1 μV	0.01	300 + 200	300	<0.5
2 V	10 μV	0.01	300 + 200	500	<0.5
10 V	100 μV	0.01	300 + 200	500	<0.5
30 V	100 μV	0.01	300 + 200	800	<0.5
100 V	1 mV	0.01	300 + 200	300	<0.5
300 V	1 mV	0.01	300 + 200	100	<0.5
600 V	1 mV	0.01	300 + 200	50	<0.5
1000 V	10 mV	0.01	300 + 200	30	<0.5

Range	Resolution	Stability (%/min)	Uncertainty (k=2) (ppm*RD+ppm*RG)	Compliance Voltage (V)	Ripple Factor(%)
20μA	100pA	0.01	300 + 200	10	<0.5
200μA	1 nA	0.01	300 + 200	9	<0.5
2mA	10 nA	0.01	300 + 200	9	<0.5
20mA	100 nA	0.01	300 + 200	9	<0.5
200 mA	1 μA	0.01	300 + 200	9	<0.5
2 A	10 μA	0.01	300 + 200	3.5	<0.5
10 A	100 μA	0.01	300 + 200	2.5	<0.5
20 A (30 A) <sup>[2]</sup>	100 μA	0.01	300 + 200	2.5	<0.5

Note[1]: RD is the reading value, RG is the range value;

Note[2]: The 30 A range is optional.

- Voltage output range: 20 mV ~ 1100 V
- Current output range: 2 μA ~ 22 A or 33 A
- Protections: voltage source short-circuit protection, current source open-circuit protection, overload protection

**6.2 AC Voltage/Current Output**

Range	Resolution	Stability (%/min)	Uncertainty (k=2) (ppm*RD+ppm*RG)	Max Burden (mA)	Harmonic (%)
200 mV	1 μV	50 μV	300 + 60 μV	500	<1.0
2 V	10 μV	0.01	300 + 200	500	<0.5
10 V	100 μV	0.01	300 + 200	800	< 0.5
30 V	100 μV	0.01	300 + 200	800	< 0.5
100 V	1 mV	0.01	300 + 200	300	< 0.5
300 V	1 mV	0.01	300 + 200	100	< 0.5
600 V	1 mV	0.01	300 + 200	50	< 0.5
1000 V	10 mV	0.01	300 + 200	30	< 0.5

Range	Resolution	Stability (%/min)	Uncertainty (k=2) (ppm*RD+ppm*RG)	Compliance Voltage (V)	Harmonic (%)
2 mA	10 nA	0.6 μA	300 +0.6 μA	50	<0.5
20 mA	100 nA	0.01	300 + 200	50	<0.5
200 mA	1 μA	0.01	300 + 200	50	<0.5
1 A	10 μA	0.01	300 + 200	15	<0.5
2 A	10 μA	0.01	300 + 200	10	<0.5
5 A	10 μA	0.01	300 + 200	5	<0.5
20 A(30 A) <sup>[1]</sup>	100 μA	0.01	300 + 200	2.5	<0.5

Note [1]: 30 A range is optional.

- Voltage output range: 20 mV ~ 1100 V
- Current output range: 200 μA ~ 22 A or 33 A
- Voltage and current output frequency: 45 Hz ~ 1100 Hz
- Protections: voltage source short-circuit protection, current source open-circuit protection, overload protection

### 6.3 Simulated DC Resistance

Range	Resolution	Uncertainty (k=2) (ppm*RD+ppm*RG)	Allowable Current
100 Ω	1 mΩ	300 + 200	1mA~80 mA
300 Ω	1 mΩ	300 + 200	1mA~80 mA
1 kΩ	10 mΩ	300 + 200	100μA~8 mA
3kΩ	10 mΩ	300 + 200	100μA~8 mA
10 kΩ	100 mΩ	300 + 200	10μA~0.8 mA
30 kΩ	100 mΩ	300 + 200	10μA~0.8 mA
100 kΩ	1 Ω	300 + 200	10μA~0.8 mA
300 kΩ	1 Ω	300 + 200	1μA~80 μA
1 MΩ	10 Ω	300 + 200	1μA~80 μA
10 MΩ	100 Ω	600 + 400	100nA~8 μA
100 MΩ	1000 Ω	3000 + 2000	10nA~0.8 μA
200 MΩ	1000 Ω	3500 + 2500	10nA~0.8 μA

- Output range: 10 Ω ~ 220 MΩ, continuously adjustable.
- Protection function: Resistor reverse connection protection

### 6.4 Sinusoidal Wave Frequency Output

Output Range <sup>[1]</sup>	Resolution	Uncertainty (k=2)
45.0000 Hz ≤ F ≤ 99.9999 Hz	0.0001 Hz	0.01%
100.000 Hz ≤ F ≤ 999.999 Hz	0.001 Hz	0.01%
1000.00 Hz ≤ F ≤ 1100.00 Hz	0.01 Hz	0.01%

Note [1]: The output mode is AC voltage or AC current.



Instrumentos de Medida, SL  
<https://idm-instrumentos.es>

Septiembre 31  
 T. 34 91 300 0191

### 6.5 AC/DC Power Output

Frequency Range (f)	Voltage Range (U)	Current Range (I)	Optimum Uncertainty (k=2) %*power output [1][2]
DC	20 mV ~ 1100 V	2 μA ~ 22 A/33 A	0.1
45 Hz ~ 65 Hz	3 V ~ 600 V	0.2 mA ~ 22 A/33 A	0.1

Note [1]: active power  $|\sin \phi| \geq 0.5$ , reactive power  $|\cos \phi| \geq 0.5$ ;

Note [2]: For more accurate technical indicators of power accuracy and power accuracy under other power factors, please refer to the calculation formula:  $U_p = \sqrt{U_U^2 + U_I^2 + U_\lambda^2}$ ,  $U_U$  is the accuracy of voltage,  $U_I$  is the accuracy of current,  $U_\lambda$  is the accuracy of power factor.

### 6.6 Phase and Power Factor Output (45 Hz~65 Hz)

Phase		Power Factor	Uncertainty (k=2)	
WATTS	VARS	$\lambda = \cos \phi$	Phase	Power Factor
0°	90°	1.0000	0.1°	0.000%
10°	80°	0.9848	0.1°	0.031%
20°	70°	0.9397	0.1°	0.064%
30°	60°	0.8660	0.1°	0.101%
40°	50°	0.7660	0.1°	0.147%
50°	40°	0.6429	0.1°	0.208%
60°	30°	0.5000	0.1°	0.302%
70°	30°	0.3420	0.1°	0.480%
80°	10°	0.1737	0.1°	0.990%
90°	0°	0.0000	0.1°	—

Note [1]: Phase range: 0.000 ° ~ 359.999 °, fineness: 0.005 °

Note [2]: Power factor range: -1 ~ 0 ~ 1, fineness: 0.000 1

Note [3]: Calculation formulas for the accuracy of other power factor:

$$U_\lambda = [1 - \cos(\phi + \Delta\phi) / \cos \phi] \times 100\%$$

**6.7 Pulse Frequency Output**

Range <sup>[1]</sup>	Resolution	Uncertainty (k=2)	Shake
1.000 00 Hz ≤ F ≤ 9.999 99 Hz	10 μHz	20 ppm*RD + 20 μHz	<20 ns
10.000 0 Hz ≤ F ≤ 99.999 9 Hz	0.1 mHz		
100.000 Hz ≤ F ≤ 999.999 Hz	1 mHz		
1.000 00 kHz ≤ F ≤ 9.999 99 kHz	10 mHz		
10.000 0 kHz ≤ F ≤ 99.999 9 kHz	0.1 Hz		
100.000 kHz ≤ F ≤ 999.999 kHz	1 Hz		
1.000 00 MHz ≤ F ≤ 2.000 00 MHz	10 Hz		
Note [1]: The output type is TTL level.			

**6.8 DC Small-signal Measurement (optional)**

Type	Range	Range	Uncertainty (k=2)
DCV	1 V	±(0~1.2) V	0.006%*RD + 0.004%*RG
	10 V	±(0~12) V	0.006%*RD + 0.004%*RG
DCI	2 mA	±(0~2.4) mA	0.006%*RD + 0.004%*RG
	20 mA	±(0~24) mA	0.006%*RD + 0.004%*RG



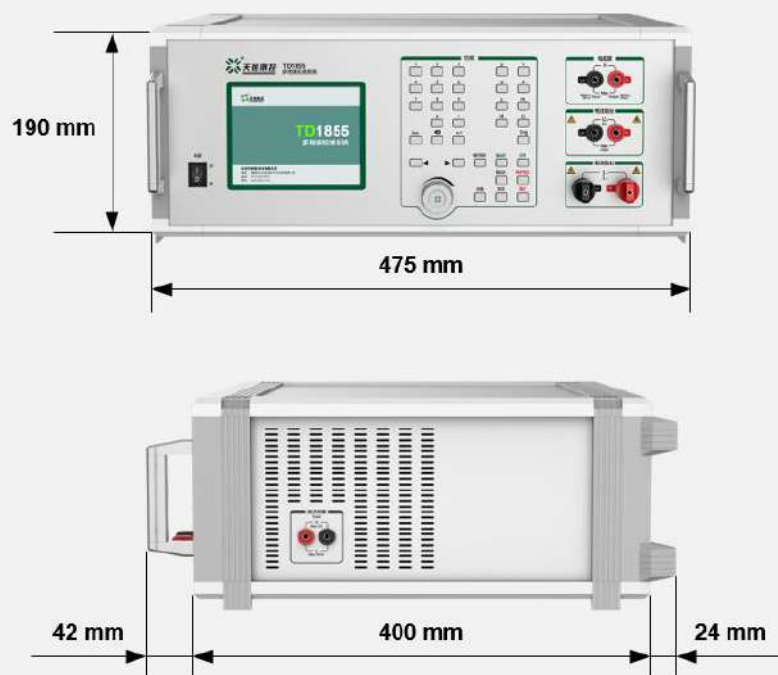



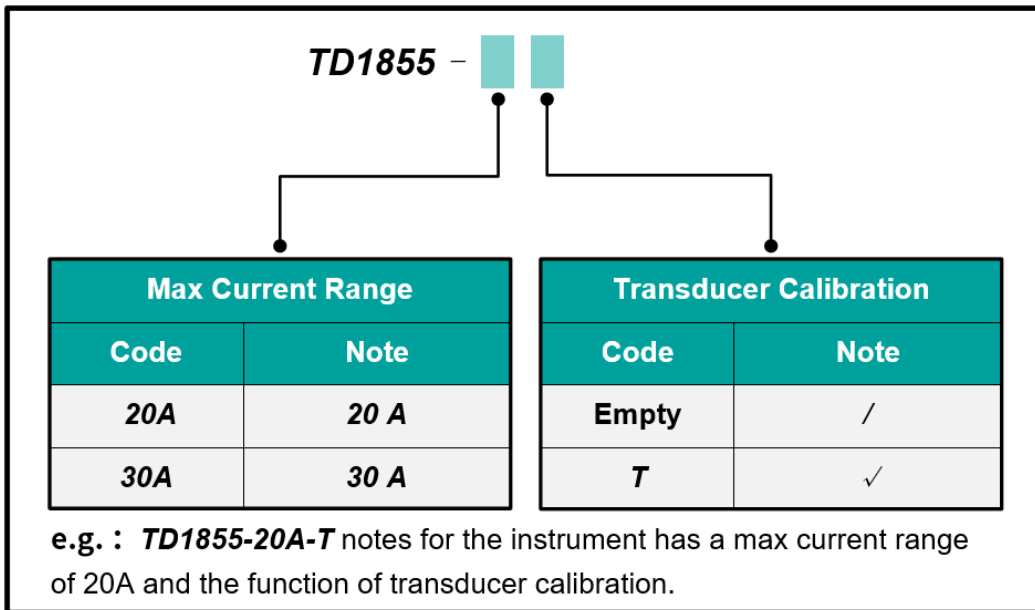



## 7. General Specifications

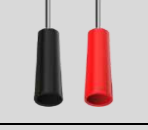

<b>Power supply</b>	AC (220±22) V, (50±2) Hz
<b>Maximum power consumption</b>	600 VA
<b>Warm up time</b>	30 minutes.
<b>Temperature performance</b>	Operating temperature: 0°C ~ 40°C Calibration temperature: 18°C ~ 28°C Storage temperature: -20°C ~ 70°C
<b>Humidity performance</b>	Operating humidity: <80% @ 30°C, <70% @ 40°C Storage humidity: (20%~80%) R·H, No condensation
<b>Altitude</b>	<3000 m
<b>Communication interface</b>	RS232
<b>Dimensions</b>	475 mm(W)× 400 mm (D) × 190 mm (H), excluding handles and feet.
	
<b>Weight</b>	About 19.5 kg

## 8. Ordering Information

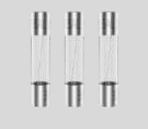







## 9. Accessories List

S/N	Pic	Name	Specification	Qty	Remark
1		Voltage Test	1.5m / 2.1mm <sup>2</sup> / Φ4-Φ4	Red 2	Standard
		Leads	safety banana plug	Black 2	accessory
2		20A Current	1.5m / 6mm <sup>2</sup> / Φ4-Φ4	Red 1	Standard
		Test Lead	safety banana plug	Black 1	accessory
3		Current	0.18m / 1.6mm <sup>2</sup> / Φ4-Φ4	Red 1	Standard
		Shorting Wire	safety banana plug	Black 1	accessory
4		Alligator Clips	Full sheath / Φ4 banana jack	Red 2	Standard
				Black 2	accessory
5		Pin Adapter	Φ2*18mm / Φ4 banana jack	Red 2	Standard
				Black 2	accessory
6		U-Shaped	Φ8 thin blade terminal / Φ4 banana jack	Red 3	Standard
		Blade Terminal		Black 3	accessory
7		Frequency	BNC Male to Alligator	1	Standard
		Test Leads	Clip		
8		Power Cord	AC 220V, 10A	1	Standard accessory
9		Glass Fuse	F3A, 250V	3	Standard accessory
10		Packing Box	Paper packaging box	1	Standard accessory

S/N	Pic	Name	Specification	Qty	Remark
1		30A current test lead	1.5m / 8mm <sup>2</sup> / Φ4-Φ4 safety banana plug	Red 3 Black 3	30A current range option
2		Transmitter auxiliary power cable	220V plug to Φ4 gun plug	1	Transmitter testing function options

Note: If the user specifies the function selection in the order contract, the corresponding accessories will be shipped by default. For example: TD1855-20A-T has a transmitter detection function, so the transmitter auxiliary power cord is included in the delivery list.

S/N	Pic	Name	Specification	Qty	Remark
1		Remote Adjustment Box	Four-terminal knob adjustment	1	Remote adjustment box options
2		Remote Adjustment Box Lead	1.5m / RS232 cable / male-male	1	Remote adjustment box options
3		Current Coil	20 A / 50 T	1	Clamp meter calibration options
4		Current Test Leads	1.5m / 16mm <sup>2</sup> / Φ12-Φ12 blade terminal	Red 1 Black 1	Clamp meter calibration options
5		Calibration software	Card USB	1	Software options
6		Communication Line	1.8m / USB to RS232 (DB9 female)	1	Software options
7		Storage Box	Aluminum alloy	1	Packaging options

Note: The above accessories need to be purchased separately and must be specified in the order contract.