



# Sherborne **Sensors**

.... the first choice in precision

## T935 Inclinometer

DC-Operated, Gravity-Referenced



### Sensor design and manufacture from a world leader in load, acceleration and inclination

Sherborne Sensors is a specialist sensor and instrumentation manufacturer that provides solutions for test and measurement, industrial, manufacturing, R&D, aerospace and defence applications globally.

[www.sherbornesensors.com](http://www.sherbornesensors.com)



In North America: Email: [nasales@sherbornesensors.com](mailto:nasales@sherbornesensors.com)  
Rest of World: Email: [sales@sherbornesensors.com](mailto:sales@sherbornesensors.com)  
Website: [www.sherbornesensors.com](http://www.sherbornesensors.com)

Sherborne Sensors, a Nova Metrix company **NX NOVA METRIX**

# T935 Miniature Servo Inclinometer

The T935 series is the next evolution of our popular and field proven T435 series. The T935 is a high precision, closed loop, gravity referenced servo inclinometer designed for use where overall space is limited. The unit can be stacked to provide dual axis X and Y measurements. Models are available in a wide variety of angle ranges. Solder pin terminations are standard.

## Features

- $\pm 1^\circ$  to  $\pm 90^\circ$  ranges
- IP65 Rated, Extremely rugged, withstands 1500g shock
- Stainless steel construction
- Stackable for X and Y measurements
- Industry Exclusive 2 Year Warranty

## Applications

- Bore Hole Mapping
- Structural Health Monitoring
- Continuous Casting Mold Alignment
- Railway Maintenance Equipment
- Mobile and Stationary Antenna Alignment

### Performance Specifications by Range @ 20°C

Range		$\pm 1^\circ$	$\pm 3^\circ$	$\pm 14.5^\circ$	$\pm 30^\circ$	$\pm 90^\circ$
Excitation Voltage	Volts dc	$\pm 12$ to $\pm 18$				
Current Consumption	mA (nom)	$\pm 15$				
Full Range Output (FRO) (see note 1)	Volts dc	$\pm 5$				
Output Standardisation	% FRO	$\pm 1$				
Output Impedance	$\Omega$ (max)	10				
Output Noise (DC to 10kHz)	Vrms (max)	0.002				
Non-Linearity (see note 2)	% FRO	0.08	0.05	0.02	0.02	0.05
Non-Repeatability	% FRO	0.02	0.01	0.002	0.001	0.0005
Resolution	Arc seconds	0.1	0.2	1.0	2.0	4.0
-3 dB Frequency	Hz	10	15	30	40	55
Sensitive Axis to Case Misalignment	Deg (max)	$\pm 0.15$	$\pm 0.15$	$\pm 0.25$	$\pm 0.50$	$\pm 1.0$
Cross Axis Sensitivity (see note 3)	% FRO	0.2				
Zero Offset (see note 4)	Volts dc	$\pm 0.08$	$\pm 0.04$	$\pm 0.04$	$\pm 0.02$	$\pm 0.02$
Thermal Zero Shift	% FRO/ $^\circ\text{C}$	$\pm 0.05$	$\pm 0.03$	$\pm 0.01$	$\pm 0.005$	$\pm 0.003$
Thermal Sensitivity	% Reading/ $^\circ\text{C}$	$\pm 0.05$	$\pm 0.03$	$\pm 0.01$	$\pm 0.006$	$\pm 0.006$

### Environmental Specifications

EMC Directive	EN 61326: 1998	
EMC Emissions	EN 55022: 1998	30 MHz to 1 GHz
EMC Immunity	EN61000-4-2: 1995 inc A1: 1998 & A2: 2001	$\pm 4$ kV
	EN61000-4-3: 2002	10 V/m
	EN61000-4-4: 2004	$\pm 1$ kV
	EN61000-4-6 1996 inc A1: 2001	3 Vrms
	EN61000-4-6: 2007	10 Vrms
EN61000-4-8: 1994 inc A1: 2001	30 A/m	
Constant Acceleration Overload	50g	
Shock Survival	1500g, 0.5 ms, $\frac{1}{2}$ sine	
Vibration Endurance	35g RMS, 20 Hz to 2000 Hz sinusoidal	
Environmental Sealing	IP65	



In North America: Email: [nasales@sherbornesensors.com](mailto:nasales@sherbornesensors.com)  
 Rest of World: Email: [sales@sherbornesensors.com](mailto:sales@sherbornesensors.com)  
 Website: [www.sherbornesensors.com](http://www.sherbornesensors.com)

Sherborne Sensors, a Nova Metrix company

**Notes**

Full Range Output is defined as the full angular excursion from positive to negative, i.e.  $\pm 90^\circ = 180^\circ$

Non-linearity is determined by the method of least squares.

Cross axis sensitivity is the output of the unit when tilted to full range angle in cross axis

Zero offset is specified under static conditions with no vibration inputs

**DIMENSIONS IN mm[INCH]**

Note: Slots and 1-72 tapped holes permit piggyback mounting two units at  $90^\circ$  to each other

PIN A : +12V to +18V dc  
 PIN B : 0V  
 PIN C : -12V to -18V dc  
 PIN D : Output  
 PIN E : Self Test

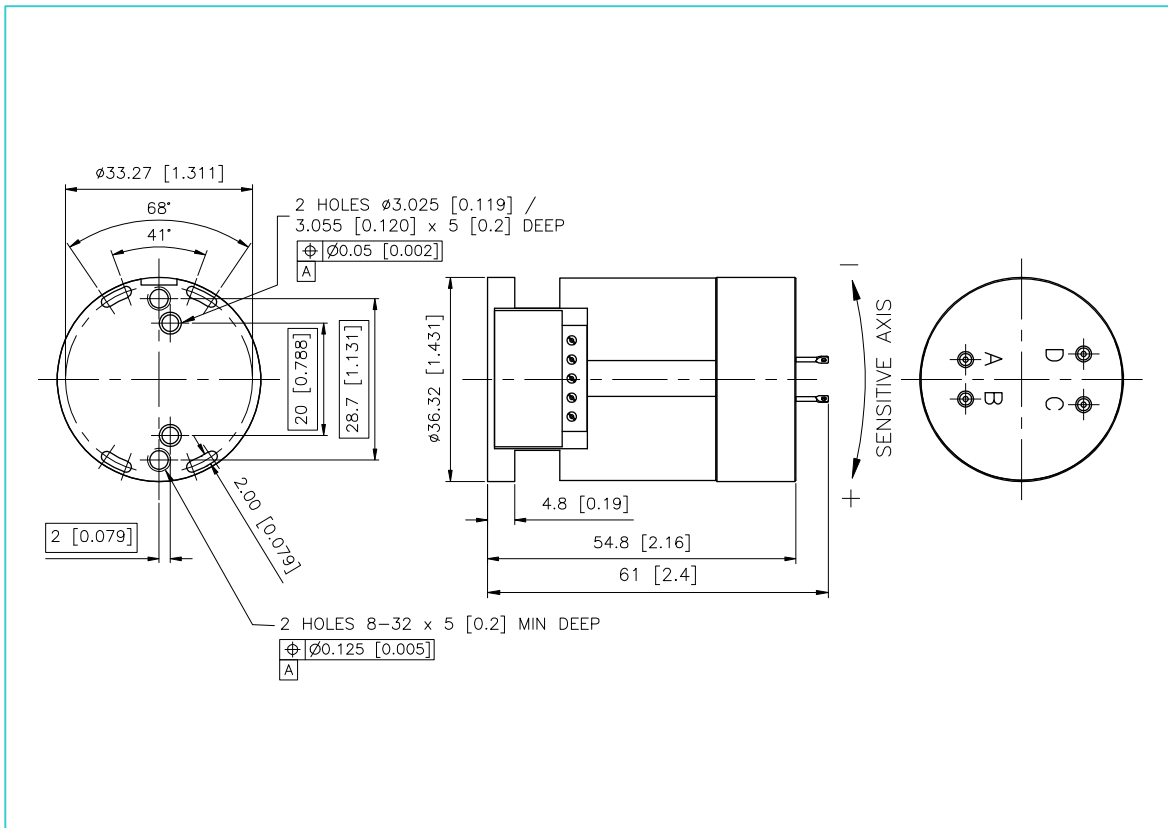
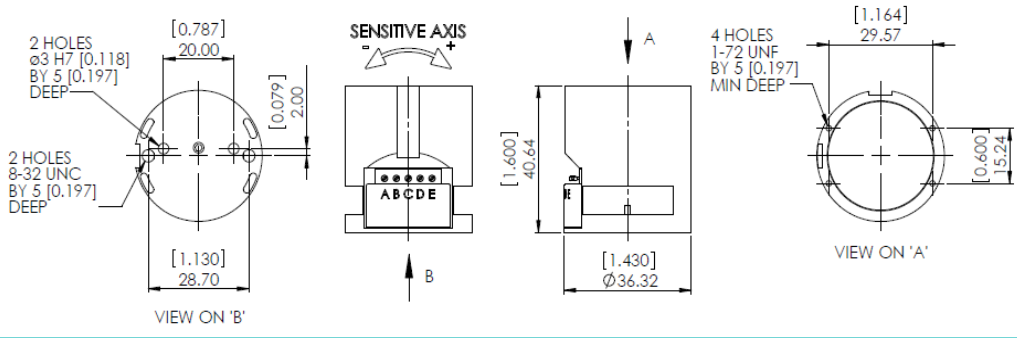

In North America: Email: [nasales@sherbomesensors.com](mailto:nasales@sherbomesensors.com)  
 Rest of World: Email: [sales@sherbomesensors.com](mailto:sales@sherbomesensors.com)  
 Website: [www.sherbomesensors.com](http://www.sherbomesensors.com)

Sherborne Sensors, a Nova Metrix company **NOVA METRIX**



## Accessories

Sherborne Sensors offers a broad range of accessories and services to enhance the performance and capabilities of our sensor products, including:

- line voltage and battery enabled power supplies
- specialized mating connectors
- cable assemblies
- high performance digital displays and universal input indicators
- repair and calibration services for all brands of accelerometers, inclinometers and load cells

## Customisation

With extensive in-house engineering capabilities, Sherborne Sensors offers not only a large range of standard sensors but also unique expertise in the design, development and manufacture of specialized sensors and systems that meet specific customer application and performance requirements.

The need to customise our sensors to the specific requirements of an application to ensure they deliver improved safety and efficiency, with optimized cost and return-on-investment is often critical to project success.

Using customer driven elements of sensor design, output and performance, Sherborne Sensors will tailor a device to meet almost any application. Major cost and performance benefits may be realized by specifying a customized sensor where performance and mechanical design are optimally matched to specific application demands.

### Contact Us

instrumentos  
de medida

SEPTIEMBRE, 31 28022 MADRID  
TEL. 91 300 01 91

[www.idm-instrumentos.es](http://www.idm-instrumentos.es)  
[idm@idm-instrumentos.es](mailto:idm@idm-instrumentos.es)