

DT8824

High Stability, High Accuracy, Ethernet Instrument Module

The DT8824 Ethernet data acquisition (DAQ) module offers the **highest stability and accuracy** for measuring analog signals. Every signal input, both analog and digital, is fully isolated from each other. This technology, ISO-Channel™, guarantees that all signals are protected from any environmental or system noise.

The high stability design of this module offers four distinct advantages:

- **10ppm accuracy**
- **a temperature coefficient of $\pm 0.05\mu\text{V}/^\circ\text{C}$**
- **a CMRR of greater than 150dB**
- **1.5 ppm maximum noise**

Key Features

- **4 simultaneous**, 24-bit analog input channels
- **Sampling frequency:** up to 4800Hz/ch
- **Input ranges** of $\pm 10\text{V}$
- **Continuously paced** analog input operations
- **Software-programmable** trigger type
- **Software calibration** of the analog input subsystem
- **4 opto-isolated** digital output lines
- **Digital outputs:** galvanically isolated to $\pm 250\text{V}$
- **Channel expansion:** up to 64 voltage inputs via the Trigger Bus
- **Ethernet** (LXI compliant) instrument module
- **$\pm 500\text{V}$ galvanic isolation:** ISO-Channel protects signal integrity
- **Includes free QuickDAQ** software...get up and running quickly



Figure 1. The DT8824 is ideally suited for chromatography, seismic, weigh scale, and medical applications where accuracy and stability are imperative.

Analog Input Channels

The DT8824 supports four, simultaneous, analog input channels, configured differentially. The DT8824 instrument module uses 24-bit, Delta-Sigma analog-to-digital converters (ADCs) that provide anti-aliasing filters based on the clock rate. These filters **remove aliasing**, which is a condition where high frequency input components erroneously appear as lower frequencies after sampling.

Input Ranges and Gains

The DT8824 supports a bipolar range of $\pm 10\text{V}$. In addition, you can choose from up to 4 gains (1, 8, 16, or 32). Table 1 lists the supported gains and effective input range of each input range on the DT8824 instrument module.

Gain	DT8824 Input Range
1	$\pm 10\text{V}$
8	$\pm 1.25\text{V}$
16	$\pm 0.625\text{V}$
32	$\pm 0.3125\text{V}$

Choose the gain that has the smallest effective range that includes the signal you want to measure. For example, if the range of your analog input signal is $\pm 1.05\text{V}$, specify a range of $\pm 10\text{V}$ for the A/D subsystem and use a gain of 8 for the channel; the effective input range for this channel is then $\pm 1.25\text{V}$, which provides the best sampling accuracy for that channel.

DT8824 ISO-Channel™

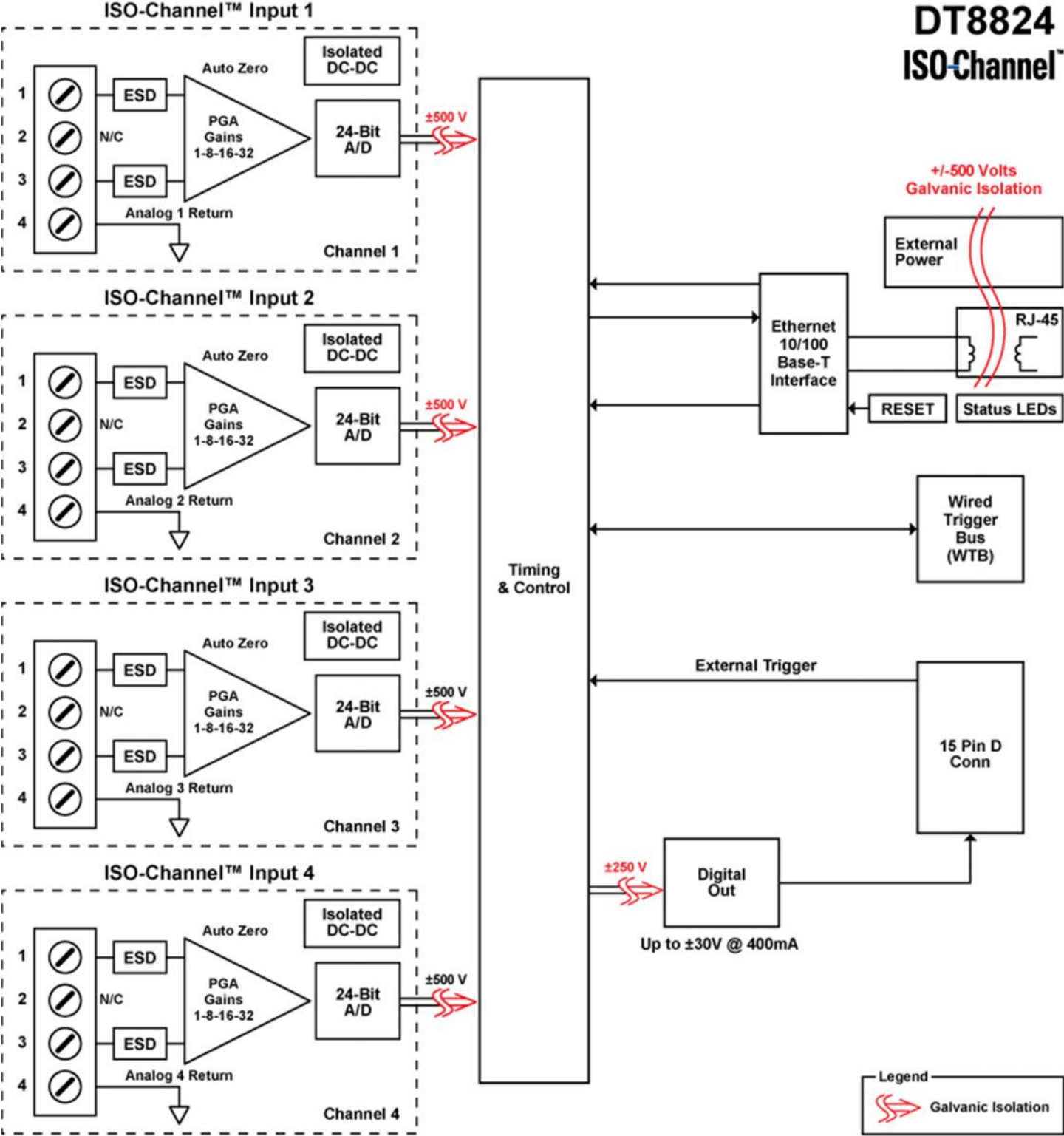

Figure 2. The DT8824 block diagram shows the 4 separate ISO-Channel analog inputs with their separate “ground” return paths. Each analog input has its own 24-bit Sigma-Delta A/D and auto-zero programmable gain amplifier to achieve unprecedented stability and accuracy.

4 Simultaneous Channels

- 24-bit sigma-delta A/D for each channel, parallel operation
- No interaction channel-channel
- $\pm 10\text{ppm}$ accuracy, $\text{CMRR} > 150\text{dB}$, $\pm 0.05\mu\text{V}/^\circ\text{C}$
- $< 5\mu\text{V}$ (1ppm) accuracy on 10V scale)

Sampling Frequency

- 1.175Hz to 4800 Hz per channel

Multi-Input Voltage Ranges

- $\pm 312\text{mV}$ full scale to $\pm 10\text{V}$

+5V Power

Uses less than 5 watts... low power to preserve stability

Ethernet LXI Compliant

Expansion to 64 Channels, Synchronously

Choice of Triggers to start measurements

4 Digital Outputs, Opto-Isolated

Drives high current, high voltage relays up to $\pm 30\text{V}$ at 400mA, AC, DC

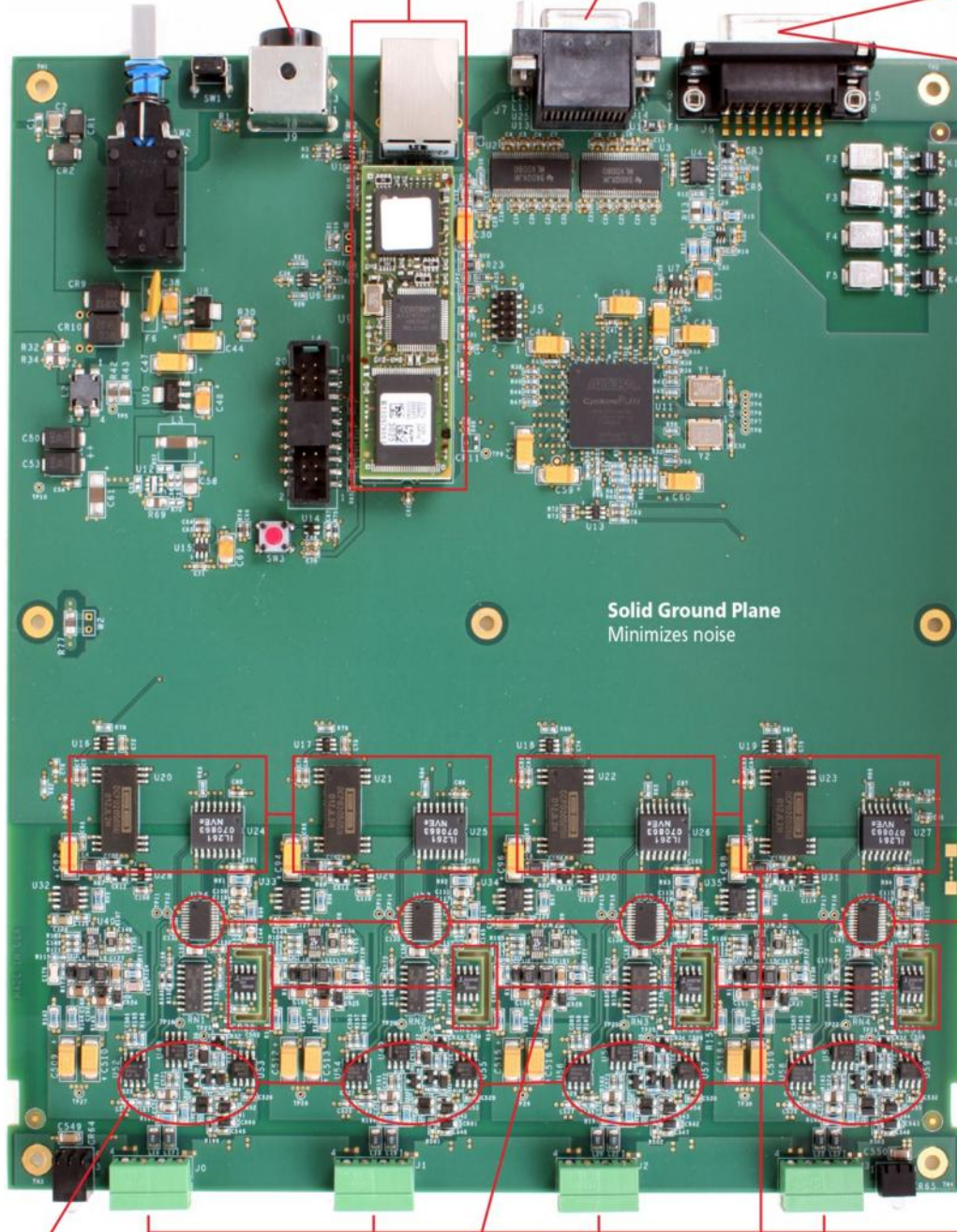

Solid Ground Plane Minimizes noise

ESD Protection

Meets all CE requirements including 8kV arc, 4kV contact

Notch-out Precision Reference for Maximum Stability

Minimizes physical and thermal stress

ISO-Channel Protection

- Eliminates noise and ground loops
- $\pm 500\text{V}$ Galvanic Isolation

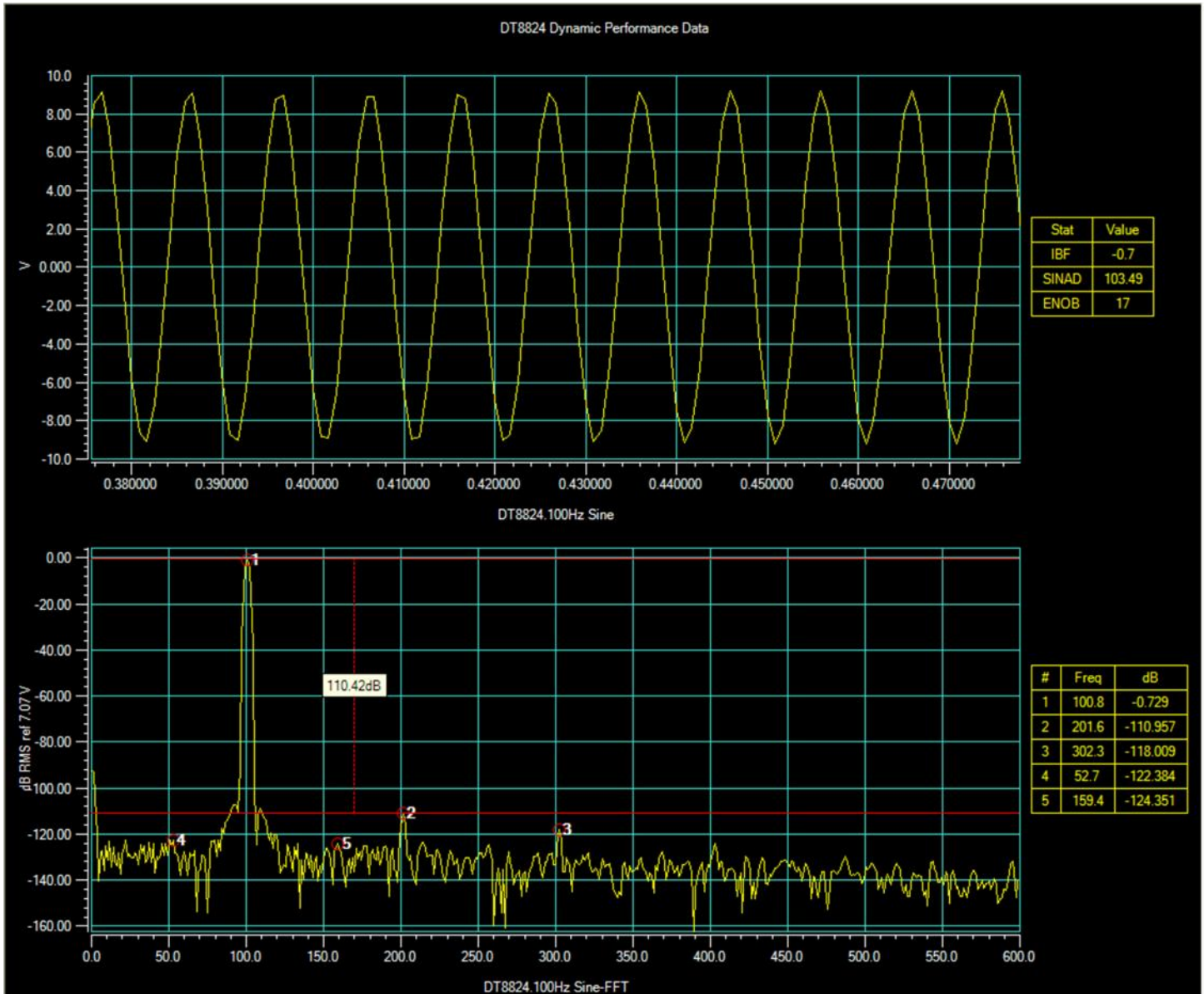

Figure 3. The dynamic performance of the DT8824 is shown with a sample rate of approximately 1kHz in the FFT graph. The ENOB (Effective Number of Bits) figure of merit for all errors is 17 bits. Also, the SFDR (Spurious Free Dynamic Range) of 110.4dB is the difference between the fundamental and 1st harmonic. With a lower sample rate of 10Hz, the ENOB rating improves to greater than 20 bit accuracy because of the smaller dynamic errors.

A/D Sample Clock

The DT8824 supports an internal master clock and an internal sync signal that synchronizes all the analog-to-digital converters on the instrument module. Use software to specify the internal clock source, the internal A/D sync signal, and the frequency at which to pace the input operations and to start the sample clock. The sampling frequency ranges from 1.175Hz to 4800Hz per channel. All channels that are specified in the analog input channel list are sampled simultaneously at the specified sampling frequency.

Input Buffer

The DT8824 uses an 8 MB input buffer for storing data from each of up to 4 enabled input channels (analog input channels 1, 2, 3, 4). One sample from each of the enabled input channels is called a scan. Specify one of the following wrap modes for the input buffer in software:

- Continuous wrap mode
- No wrap mode

Triggers

A trigger is an event that occurs based on a specified set of conditions. Once the analog input subsystem is armed using software (and if the trigger source is immediate, started using software), acquisition starts when the instrument module detects the initial trigger event and stops when either the input buffer has been filled (if no wrap mode was selected), or you stop the operation (if continuous mode is selected).

The DT8824 supports the following trigger sources for starting analog input operations:

- Software trigger
- External trigger
- Trigger bus
- LAN trigger packet

Digital Output Lines

The DT8824 features four latched and isolated digital output lines. **The outputs are solid-state relays that operate at ±30V and 400mA peak (AC or DC)**

The DT8824 includes channel-to-channel isolation of up to ±250V between digital output lines.

Sync up to 64 channels

Up to 16 instrument modules can be stacked for parallel operation of 64 voltage inputs. These modules are synchronized via the Wired Trigger Bus and can be externally triggered in various ways.

Synchronize the start of acquisition on multiple instrument modules using LXI triggers on the Trigger Bus or LAN trigger packets. To make the clock synchronous, use the Trigger Bus.

Using the Trigger Bus

Up to 16 LXI devices can be connected together using the Trigger Bus. DT8824 can be connected using a daisy-chain configuration, as shown in Figure 4, using the 25-pin J7 Trigger Bus connectors.

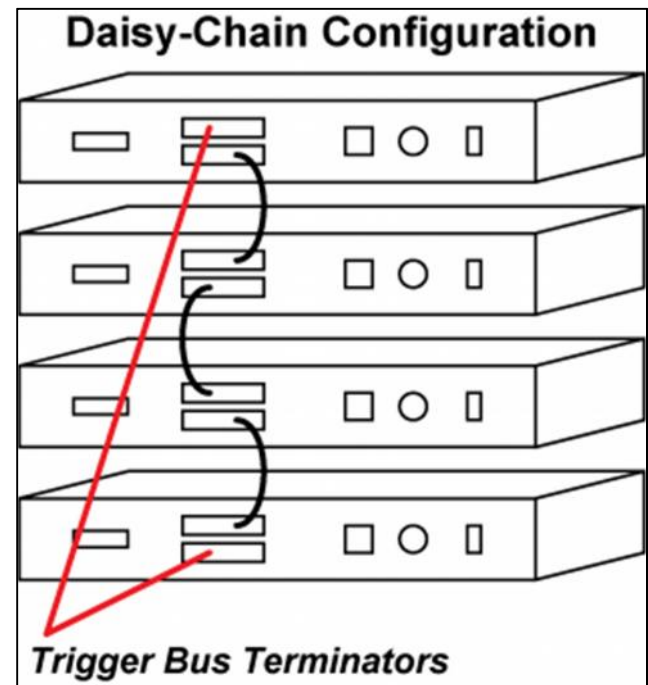

Figure 4. Multiple DT8824 modules in daisy-chain configuration.

LAN Trigger Packets

When multiple DT8824 modules are connected together over the local area network (LAN), as show in Figure 5, you can synchronize the start of acquisition by transmitting one of eight LAN trigger packets (LAN0 to LAN7) over the network.

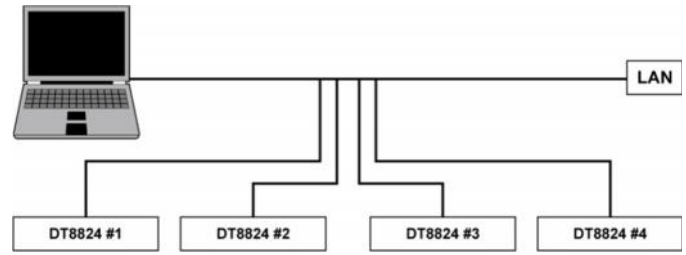

Figure 5. Synchronizing the start of acquisition when triggering instrument modules over the LAN.

QuickDAQ

QuickDAQ allows you to acquire and display from all Data Translation USB and Ethernet data acquisition devices that support analog input streaming. Combine QuickDAQ with Data Translation hardware to acquire data, record data to disk, display the results in both a plot and digital display, and read a recorded data file. Be productive right out of the box with this powerful data logging software. Data can be exported to other applications like Microsoft Excel® and The Mathworks MATLAB® for more advanced analysis. Two additional options can be purchased to add FFT analysis capabilities to the base package.

Key Features:

- **QuickDAQ Base Package (Free)**

- Ready-to-measure application software
- Configure, acquire, log, display, and analyze your data
- Customize many aspects of the acquisition, display, and recording functions to suit your needs

- **FFT Analysis Option (License Required)**

- Includes all the features of the QuickDAQ Base Package
- Perform single-channel FFT operations including:
 - ◊ Auto Spectrum
 - ◊ Spectrum
 - ◊ Power Spectral Density
- Configure and view dynamic performance statistics

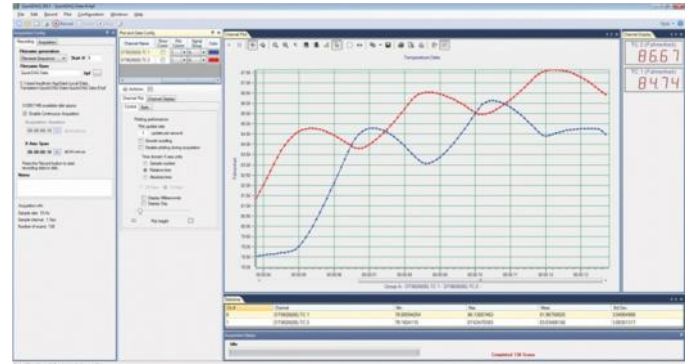

Figure 6. QuickDAQ ships free-of-charge and allows you to get up and running quickly.

- Supports Hanning, Hamming, Bartlett, Blackman, Blackman Harris, and Flat Top response windows
- **Advanced FFT Analysis Option (License Required)**
 - Includes all the features of the QuickDAQ Base Package and FFT Analysis Package
 - Perform 2-channel FFT operations including:
 - ◊ FRF
 - ◊ Cross-Spectrum
 - ◊ Cross Power Spectral Density
 - ◊ Coherence
 - ◊ Coherent Output Power
 - Supports real, imaginary, and Nyquist display functions
 - Additional FFT analysis functions supported: Exponential, Force, Cosiner Taper
 - Save data to .uff file format

Other Software Options

The following software is available for use with the DT8824 module and is on the CD included with your hardware:

- **Eureka Discovery Utility** – This utility helps you locate or “discover” all LXI (Ethernet) instruments that are connected to your system and provides the following information about your instrument: the IP address, manufacturer, model number, serial number, and version of the firmware that is running on your instrument. In addition, you can use this utility to configure Windows firewall settings and update the firmware for your Data Translation LXI instrument module.

- **DT8824 Web Interface** – This built-in interface allows you to verify the operation of your DT8824 instrument module and perform basic functions using a web browser and no additional software. Using it, you can configure your instrument module, measure input signals, and save results to disk.

- **DT8824 IVI-COM driver** – This driver provides access to the DT8824 instrument module functions through a COM server. The IVI-COM driver works in any development environment that supports COM programming, including MATLAB, Visual Basic.NET, Visual C#.NET, Agilent VEE Pro, LabVIEW, LabWindows, and others.

- **SCPI commands** – Use SCPI commands to program DT8824 LXI instrument modules. Refer to the SCPI Programmer’s Manual for the DT8824 (UM-24017) for information on the supported SCPI commands and example programs.

DT8824 Web Interface

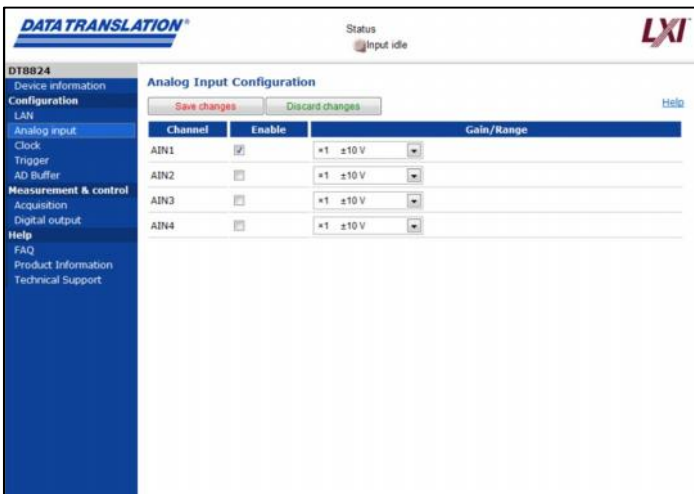

Figure 7. The main web page displays information about your instrument module on the network.



Figure 8. The configuration web pages are used to setup your analog input parameter.



Figure 9. The measurement and control web pages are used to start or stop data acquisition and display live data in a numerical channel.

Accessories

The following optional accessories are available for the DT8824:

- **EP377** Trigger Bus cables (25-pin, .5M)
- **EP380** Single Rack-mount kit –To rack mount a single DT8824 instrument module.
- **EP379** Dual Rack-mount kit – To rack mount two DT8824 instrument modules side by side.

Ordering Summary

Instrument Module

- **DT8824** - $\pm 10V$ Input Range

Accessories

- **EP377** – Trigger Bus Cables (25-pin, .5M)
- **EP380** – Dual-Rack Mount Kit
- **EP379** – Single-Rack Mount Kit

All Data Translation hardware products are covered by a 1-year warranty. For pricing information, please visit our website or contact your local reseller.



instrumentos
de medida

Septiembre, 31 28022 Madrid
Tel. 913000191 Fax. 913885433

www.idm-instrumentos.es
idm@idm-instrumentos.es