

BS01 BELT HEAT FLUX SENSOR

The BS01 is a large-area flexible heat flux and temperature sensor for in-situ evaluation of the insulation value of pipes. With years of experience put into the design, it is the "standard" for pipe insulation testing for subsea oil pipes.

INTRODUCTION

The BS01 contains three heat flux sensing areas and four integrated temperature sensors. Originally designed for "simulated service conditions testing" for subsea oil pipelines, it can withstand high hydrostatic pressures up to 110 bar and is (contrary to other sensors) completely water-tight. The main development effort has gone into the prevention of penetration of moisture into the sensor at high pressures. With other sensors not specifically prepared for the high pressure, penetrated moisture will on the long term lead to instability of the sensor calibration.

The sensor is provided with a mounting set for easy fixation, consisting of a cover and two springs.

BS01 was originally designed by TNO TPD. Scientific publication about this sensor: D. Haldane (Heriot Watt University), F. van der Graaf, A.M. Lankhorst (TNO TPD): A direct Measurement System to obtain the Thermal Conductivity of Pipeline Insulation Coating Systems under Simulated Service Conditions.

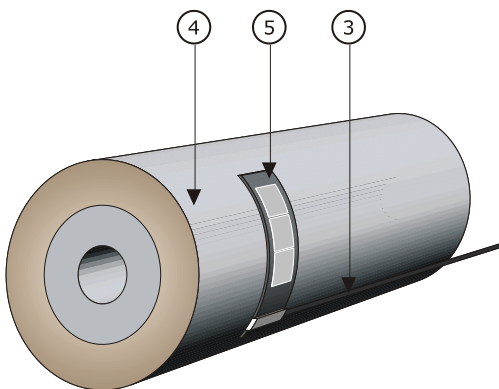

Figure 1

*BS01 on pipe during in service testing.
3 Cabling, 4 Pipeline to be tested
5 BS01 mounted on pipeline (cover and springs for fixation are not shown)*

BS01 SPECIFICATIONS

Heat flux measurement:	3 separate heat flux sensors
Temperature measurement:	4 type K thermocouples
Flexibility:	30 mm minimum radius
Sensitivity (nominal):	50 $\mu\text{V}/\text{Wm}^{-2}$
Expected accuracy (to 50°C):	within 2.5 %
Temperature coefficient of the calibration coefficient:	- 0.17 %/°C
Temperature range:	0-100 °C
Pressure range:	1-110 bar
Cover dimensions:	140 x 360 mm

SUGGESTED USE

- General pipeline insulation testing
- Simulated service testing for subsea pipelines