



WOUND COMPONENT EST ANALYZER MODEL 19036

Chroma 19036 is the industry's first Wound Component Electrical Safety Test (EST) Analyzer that combines the functions of impulse test, hipot, insulation resistance and DC resistance measurements. It has 5kVac/ 6kVdc high voltage output, 5kV insulation resistance, 6kV layer short impulse voltage and 4-wire DC resistance measurement that can comply with the wound components test demands by providing maximum 10 channels output for multichannel scanning tests to save time and labor costs.

The test items for wound components include AC/DC hipot test, IR test, IWT (Impulse Winding Test) and DCR (DC Resistance). Chroma integrates the above tests into 19036 Wound Component EST Analyzer that can perform safety tests on wound components like motors, transformers and solenoid valves to verify their quality.

Poor insulation of coil often causes layer short, cross-line short or pin short during usage, and the reason could be initial design error, poor fabrication process or bad insulation material. Thus, to add layer short test in the electrical safety test manufacturing process can complete the scanning test for multiple windings at once to increase the quality of wound components.

Combining the layer short testing function, the 19036 has 6kV impulse voltage with area, differential area, Flutter and Laplacian judgments to supply effective measures for inspecting poor coil insulation.

The 19036 is equipped with a patented 4-wire DC resistance test that has both Drive and Sense in compliance with withstanding specification to provide 10 channels of 4-wire DC resistance test functions. Up to 40ch of scanning test can be conducted when the 19036 is configured with 16ch scan boxes.

The 19036 also has HSCC functions to scan multiple windings rapidly for normal connection. It can solve the test fail problems caused by bad contact of cabling or test fixture.

The motor standard such as UL 1004-1 requires high power safety tester. Chroma 19036 with the capability of outputting & measuring AC100mA/DC 20mA is suitable for testing large leakage current or big electrical safety equipment. Chroma 19036 as a comprehensive tester integrated with high power hipot test and other safety tests can bring the maximum benefit to the production line as well as to quality assurance. Its 500VA design is also compliant with the output power requirements of EC/UL.

MODEL 19036

Key Features :

- 5 in 1 (10 channels) composite analyzer (ACVV / DCWV/ IR / Impulse / DCR)
 - Hi-pot test
 - 5kVac / 6kVdc
 - HSCC(High Speed Contact Check)
 - 500 VA output
 - Insulation Resistance test
 - 5kV Max.
 - Impulse Winding Test (IWT)
 - 6kV impulse voltage
 - High sampling rate (200MHz)
 - DCR measurement
 - 4-wire DCR measurement
 - Δ / Y motor winding calculation
- Support max. 40 channels scanning test
- English, Traditional Chinese and Simplified Chinese User Interface
- USB waveform storage& Hard copy function
- Graphic color display
- Standard LAN,USB,RS232 interface
- GFI (Ground Fault Interrupt) for body protection



Chroma



MEASUREMENT TECHNOLOGY

HI-POT TEST FLASHOVER DETECTION(ARC)

Fast transient on detected leakage current is defined as flashover in hi-pot test. The 19036 has Flashover Detection as other Chroma safety test series. Flashover is non-sequential discharge generated by the inner or surface of insulation component which cause DUTs to lose original insulation feature, generated carbonation electrically conductive path and damages the product. As flashover cannot be detected by leakage current rms value, Flashover Detection is one of the inevitable inspection items in HV test.

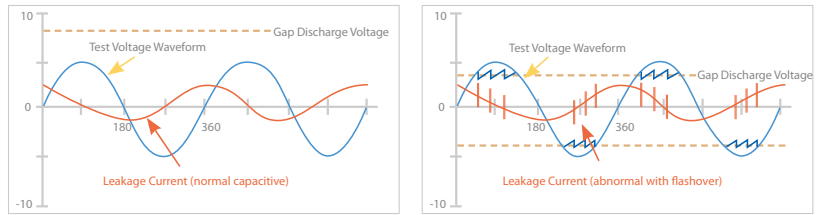

IMPULSE TESTING OVERVIEW

The impulse winding test is to impose a non-destructive, high speed and low energy voltage impulse on the DUT (Device Under Test) to analyze/compare the equivalent waveform of yield and defect products for good and no good judgement. The main function of impulse winding test is to discover the potential defects such as layer short, corona or partial discharge that is difficult to find in wound components in the early phase.

FOUR KINDS OF WAVEFORM JUDGEMENT FOR TESTING

- Area size
- Differential area
- Flutter value
- Laplacian value

Use Laplacian for calculation can detect the waveform discontinuity caused by electrical discharge effectively.

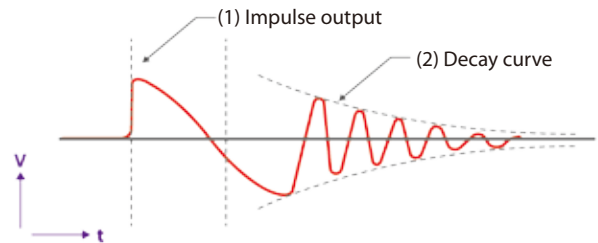

DCR MEASUREMENT

■ DCR Measurement (two-wire/four-wire)

Chroma 19036 can choose to use 2-wire or 4-wire DCR measurements. The new patented port design provides maximum 10 channels 4-wire DCR measurements for high accuracy tests on multiple wound samples like motors and transformers. The measurement range is from 0.1mΩ to 500KΩ.

■ DCR Balance

When the DCR of the motor with 3 windings is unbalanced, the rotation will not be balanced as well and it could cause bad quality for long term use. The judgement of DCR balance is to subtract the maximum and the minimum value of winding and the product is no good if the value exceeds the set range. It is a reliable assistant tool for testing motor products.

■ Temp Compensation

When measuring a smaller DCR, it often encounters the problem of temperature difference. The measured resistance is varied with the temperature. Thus, the temp compensation function is included in the 19036. Through the conversion of temperature coefficient, it changes the DCR to the measured value under standard temperature to reduce the influence caused by temperature difference.

HIGH SPEED CONTACT CHECK (HSCC)

If an open occurs to electrical safety testing circuit it may cause a defected product to be judged as a good one. The contact check can detect and screen the products when short circuit occurs to reduce the damage of fixture device and save the test cost.

The HSCC function can scan rapidly if the DUT circuit contact is correct. This new technology allows the contact check before hipot test to be done faster than ever. The 19036 also has High Frequency Contact Check (HFCC) and Open Short Check (OSC, Patent no. 254135) functions that can detect if there is Open (bad contact) or Short (DUT short circuit) between the winding and the iron core.

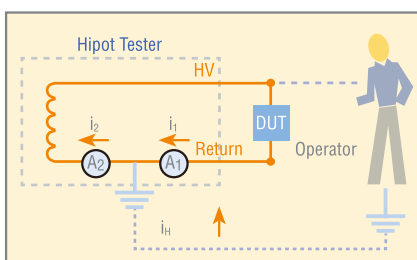
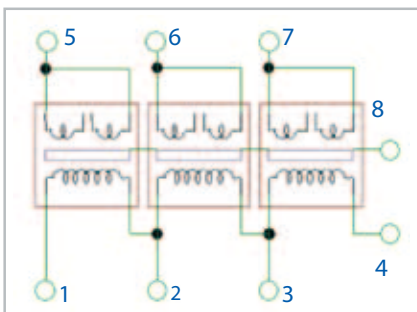

SUB-STEP FOR TESTING MULTIPLE WOUND COMPONENTS

Parallel hipot test is often used to improve the manufacturing inspection speed; however, it is unable to set the current high/low limit correctly when doing a parallel test and it causes the leakage of defected products or misjudging the good to no good. It also adds workstations for testing the defected products and increases the cost. The 19036 offers the sub-step function to solve the trouble caused by the parallel test. When the parallel test is required for production, it programs fail as the sub-step launch condition which means only when the main test item (parallel) fails the sub-step test item (single) will be performed to judge the defect DUT. The implementation of this function can optimize the productivity and quality inspection.

例 : Step 1 : AC Hipot / pin1 to pin5, 6, 7

- Sub step 1.1 : AC Hipot / pin1 to pin5
- Sub step 1.2 : AC Hipot / pin1 to pin6
- Sub step 1.3 : AC Hipot / pin1 to pin7

GFI HUMAN PROTECTION

The ultimate purpose of safety testing is to protect users from electrical hazard. The 19036 also has GFI function to protect the operator. The GFI function can cut off the power output immediately while the human body is suffering electric shock. The GFI function detects the current from earth GND (operator) and LOW terminal (device). The voltage output will be cut off if the current is over 0.5mA

APPLICATIONS

PRODUCT APPLICATIONS

From EV motors, servomotors, ascension motors to fans all rotary motor products need to perform impulse test, hipot test and DCR measurements to ensure the product quality also refer to JB/T 7080 GB Machinery Industry Standard for testing.

The DCR measurement of the 19036 is in 4-wire type and each terminal has Drive and Sense total 10 independent channels for scanning test 3 DUTs at once to increase productivity. Each channel can be set to Hi/Lo/Open respectively.

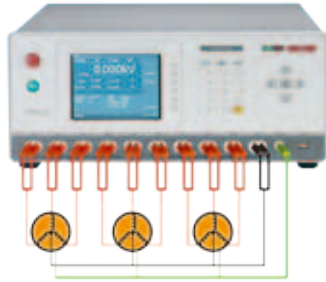

■ Y-type motor for example, the test items are:

- HSCC / OSC
- DCR Test
- Impulse Test
- Hi-pot -Sub step test

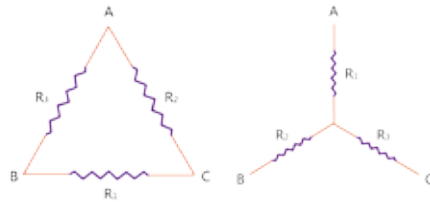

■ Δ-type and Y-type motor

To solve the problem of unable to do DCR measurement on the Δ -type and Y-type motor winding (no center-tapped) directly, Chroma 19036 has added Δ -type and Y-type motor winding DCR calculation functions to obtain the value of R1, R2 and R3.

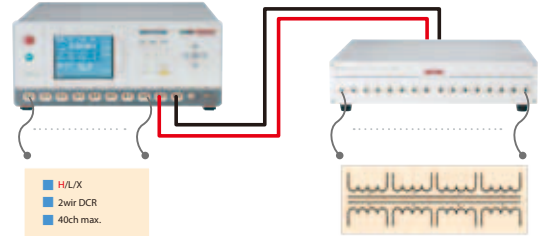

■ 40 Channels scanning test

A190359/A190362(4-wire) scanner has 16 test channels and each of them can be set to H (High voltage, Hi), L (High voltage, Lo) or X (Open). The combination of 19036 and A190359/A190362(4-wire) can apply to multiple PINs or small amount but diversified DUTs as well as cell type production line to complete all tests within one station.

PANEL DESCRIPTION

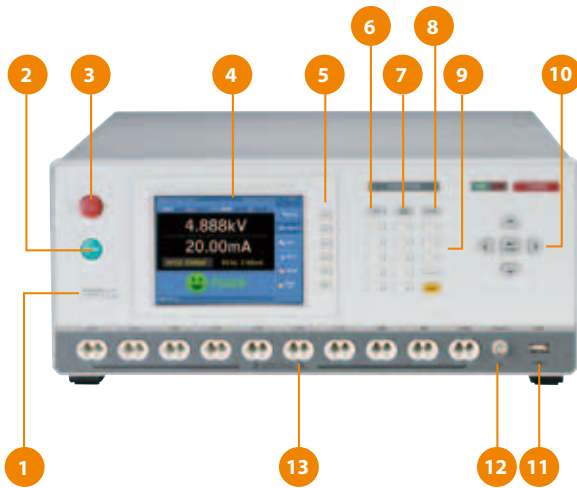

- | | |
|----------------------|---------------------------------|
| 1. Power switch | 8. System key |
| 2. Start button | 9. Data entry keys/Program keys |
| 3. Stop button | 10. Arrow and Enter key |
| 4. LCD color display | 11. USB storage interface |
| 5. Function key | 12. RTN/LOW terminal |
| 6. Test key | 13. Test terminal |
| 7. Main index key | |

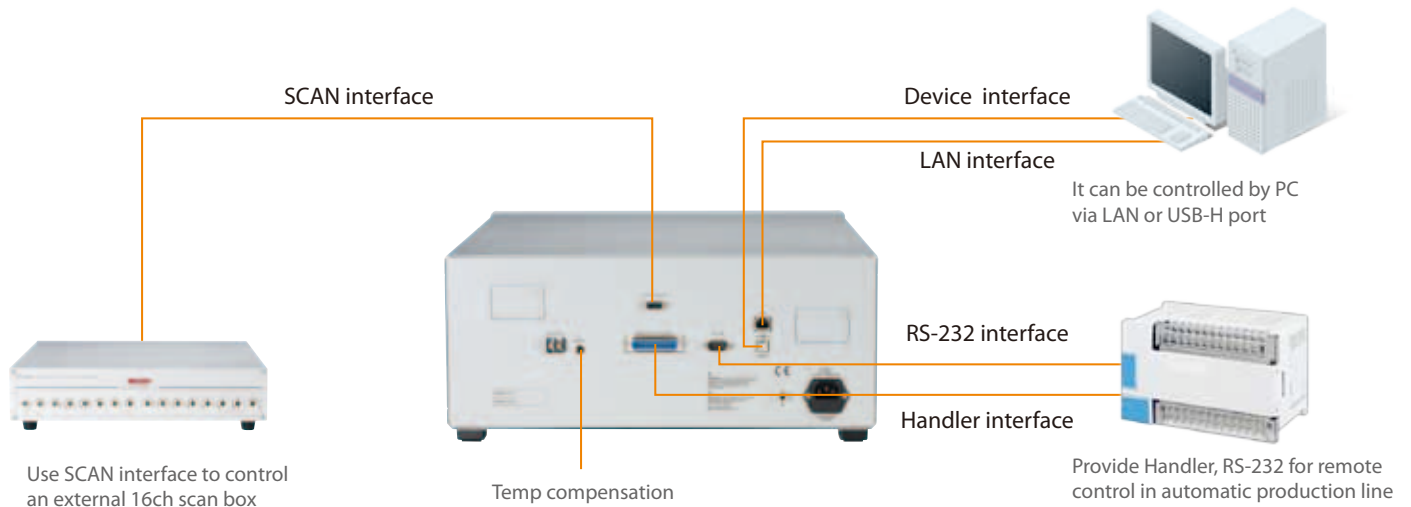

SPECIFICATIONS

Model		19036
AC/DC Withstanding Test		
Output Voltage		AC: 0.05~5.0kV / DC : 0.05~6.0kV
Load Regulation		≤(1% of output + 0.1% of full scale)
Voltage Accuracy		± (1% of setting + 0.1% of full scale)
Voltage Resolution		2V
Cutoff Current		AC: 0.001mA~120mA (Voltage ≤4kV) AC: 0.001mA~100mA (Voltage >4kV) DC: 0.0001mA~20mA
Current Accuracy		± (1% of reading + 0.5% of range)
Test Timer		Test time:0.3 ~ 999 sec., and continue Ramp / Fall / Dwell time:0.1 ~ 999 sec., and off
Output Frequency		50Hz / 60Hz (for AC)
Waveform		Sine wave (for AC)
Insulation Resistance Test		
Output Voltage		DC : 0.050 ~ 5.000kV, Steps : 0.002kV
Load Regulation		≤(1% of output + 0.1% of full scale)
Voltage Accuracy		± (1% of setting + 0.1% of full scale)
IR Range		0.1MΩ ~ 50GΩ
Resistance Accuracy	>1kV	1MΩ ~ 1GΩ : ± (3% of reading + 0.1% of full range) 1GΩ ~ 10GΩ : ± (7% of reading + 2% of full range) 10GΩ ~ 50GΩ : ± (10% of reading + 1% of full range)
	≥0.5kV and ≤1kV	0.1MΩ ~ 1GΩ : ± (3% of reading + 0.1% of full range) 1GΩ ~ 10GΩ : ± (7% of reading + 2% of full range) 10GΩ ~ 50GΩ : ± (10% of reading + 1% of full range)
	<0.5kV	1MΩ ~ 1GΩ : ± (5% of reading + (0.2*500/Vs)% of full scale)
Impulse Winding Test		
Applied Voltage, Step, and Energy		0.5 ~ 6kV ,10V Step ,Max 0.21 Joules
Inductance Test Range		More than 10uH
Sampling Speed		10bit / 5ns (200MHz)
Sampling Range		11 Ranges
Pulse Number		Pulse Number: 1~32, Dummy Pulse Number: 0~9
Detection Mode		Area / Differential Area : Flutter/ Laplacian Detection
DC Resistance Measurement		
Test Signal		<DC 10V , <DC 200mA
Measurement Range		0.1mΩ ~ 500kΩ
Measurement Accuracy	100mΩ	± (0.5% of reading + 1% of full range)
	1Ω	± (0.5% of reading + 0.2% of full range)
	10Ω	± (0.5% of reading + 0.05% of full range)
	100Ω	± (0.5% of reading + 0.05 % of full range)
	1kΩ	± (0.5% of reading + 0.05 % of full range)
	10kΩ	± (0.5% of reading + 0.05 % of full range)
100kΩ	± (0.5% of reading + 0.05 % of full range)	
Flashover Detection		
Detection Current		Programmable setting AC : 20mA ; DC : 10mA
Contact Check Function		
Contact Check		OSC (open/short check) HFCC (High Frequency Contact Check) HSCC (High Speed Contact Check; winding DCR check)
Electrical Hazard Protection Function		
Ground Fault Interrupt		0.5mA ±0.25mA AC, ON/OFF
Key Lock		Yes (password control)
Interlock		YES
Indication, Alarm		GO : Short sound, Green LED; NG : Long sound, Red LED
Memory Storage		200 sets, max. 40 steps per set
Interface		
Standard : RS232, Handler ,USB , LAN interface		
General		
Operation Environment		Temperature: 0°C ~ 45°C, Humidity: 15% to 95% R.H@ ≤ 40°C
Power Consumption		No Load: <150VA ; Rated Load: <1000VA
Power Requirements		90 ~ 264Vac, 47 ~ 63Hz
Dimension (W × H × D)		428 × 177 × 500mm / 16.850 x 6.969 x 19.685 inch
Weight		26kg / 57.32 lbs

ORDERING INFORMATION

19036: Wound Component EST Analyzer
A190359 : 16ch HV External Scanning BOX
A190360 : 19' Rack Mount Kit

A190362 : 16ch 4-wire HV External Scanning Box
W25 000099 : 4-wire Test Cable with bare wire(3m)
W25 000100 : 4-wire Test Cable with bare wire(1.5m)

W25 000104 : 4-wire Test Cable with Clip

Developed and Manufactured by :

CHROMA ATE INC.
 致茂電子股份有限公司
 總公司
 66 Hwaya 1st Rd., Kueishan
 Hwaya Technology Park,
 Taoyuan County 33383,
 Taiwan
 Tel: +886-3-327-9999
 Fax: +886-3-327-8898
<http://www.chromaate.com>
 E-mail: info@chromaate.com

CHINA
CHROMA ELECTRONICS
(SHENZHEN) CO., LTD.
 8F, No.4, Nanyou Tian An
 Industrial Estate, Shenzhen,
 China PC: 518052
 Tel: +86-755-2664-4598
 Fax: +86-755-2641-9620

JAPAN
CHROMA JAPAN CORP.
 472 Nippa-cho, Kouhoku-ku,
 Yokohama-shi, Kanagawa,
 223-0057 Japan
 Tel: +81-45-542-1118
 Fax: +81-45-542-1080
<http://www.chroma.co.jp>
 E-mail: info@chromaate.com

U.S.A.
CHROMA SYSTEMS
SOLUTIONS, INC.
 19772 Pauling, Foothill Ranch,
 CA 92610
 Tel: +1-949-600-6400
 Fax: +1-949-600-6401
<http://www.chromausa.com>
 E-mail: sales@Chromausa.com

Worldwide Distribution and
 Service Network

instrumentos
de medida
 Septiembre 31. 28022 Madrid
 Tel. 91 300 0191 Fax. 31 388 5433
ids@idm-instrumentos.es