

Features

- DSP technology
- 0 - 750 psid pressure range
- Intelligent pressure modules
- Dual pressure ranges available
- $\pm 0.05\%$ full scale accuracy (most ranges)
- 625 samples/channel/second
- Temperature compensated pressure sensors

General Description

Model DSA3016, Digital Sensor Array, is a rack mounted module designed for multiple pressure measurements. Each DSA3016 module incorporates 16 temperature compensated piezoresistive pressure sensors, along with a pneumatic calibration valve. Field replaceable sensors assure that downtime is minimized in the unlikely event of sensor damage. Up to 8 DSA3016 Digital Sensor Array modules can be used in a 19 inch rack enclosure, Model DSAENCL4000.

The DSAENCL4000 pressure acquisition system represents the next generation of intelligent electronic pressure scanning.

The state-of-the-art DSP technology is at the heart of our new 19 inch rack mounted DSAENCL4000 enclosure. Located on the backplane of the enclosure, the Digital Signal Processor (DSP) is a programmable device capable of extremely fast math functions that operate on the data stream in real time. All measurements are converted into Engineering Units.

Advantages of DSP technology:

- Boots up quickly
- Real Time Operating System
- Low Data Latency

The DSAENCL4000 uses a micro SD card to store all configuration and module data. The SD card is easily removed if needed for security reasons. The enclosure utilizes a pressure temperature look-up table to compensate the pressure sensors for temperature changes, effectively negating any thermal errors.



*DSA3016/16Px
Digital Sensor Array*

The DSP processor also controls the actuation of an internal calibration valve to perform on-line zero calibrations. Long term system accuracy is achieved for up to 6 months.

All DSA3016 modules manufactured after first quarter 2004 have an ID chip installed. The DSAENCL4000 DSP processor reads the serial number, pressure range, etc. of each DSA3016 module and its location in the enclosure from the DSA module ID chip.

Applications

The DSA3016 (Digital Sensor Array) is ideal for measuring pressures on turbomachinery, turbine engines, compressors, and other applications where precision pressure measurements are required. The DSA temperature compensated pressure sensors are over ten times more stable over the entire temperature range than typical piezoresistive pressure sensors. Up to 8 DSA3016 pressure modules are supported by a DSAENCL4000 enclosure, totalling 128 pressure inputs per enclosure.

DSA3016 modules have a front panel power cut-off switch that allows them to be "Hot Swappable" without having to power down the system. They also have an illuminated power switch that blinks when scanning. The DSAENCL4000 enclosure has an Ethernet link and activity LED on the front.

DSA3016 pressure modules will work with all DSAENCL3000, 3200, and 4000 series enclosures.

DSA3016 Features and Options

On-line Sensor Compensation and Calibration

The DSA3016 incorporates individual pressure sensors are each uniquely thermally compensated and individually packaged in rugged, field-replaceable housings. Additionally, the transducers are factory calibrated over their full pressure and temperature ranges. The resultant calibration data are stored in a look-up table in FLASH memory.

The design includes integral pneumatic calibration valves, which allows for “quick zero” correction. When actuated, the positive side of the pressure sensors are pneumatically shorted to the reference manifold, creating a zero pressure differential. The sensor offsets are then recorded.

DSA Calibration Valve Control Pressure

The DSA3016 calibration valves are “Normally Px” where no control pressure, or a loss of control pressure, defaults the DSA calibration valve to the operate (sense) mode. 90 psi control pressure is required to switch the DSA calibration valve into purge, calibrate or isolate mode.

Dual Range

Each group of 8Px (pressure inputs) contains its own calibration valving and reference connector, thus a single DSA3016 module can incorporate up two unique pressure ranges for maximum flexibility.

Isolate Purge Feature

A manifold purge feature is incorporated in the DSA calibration valve. This purge method isolates all of the pressure sensors from the purge pressure. It is an ideal method for eliminating condensation, oil, dust or other contaminants in the pressure input tubing. This technique permits the safe use of high purge pressures without damaging the pressure sensors due to overpressure.

Common vs. Individual Reference

DSA3016 Digital Sensor Arrays are available in two basic model types, common and individual reference. Common reference configurations are standard and allow the user access to each individual sensor’s positive side, while the reference (or negative) sides are manifolded in groups of eight. Individual reference versions are available with each sensor having an individual reference input.

High-Line Low Delta P Measurements

An optional rack mounted pressure module is available that incorporates a special pneumatic design, which allows for a higher accuracy reading of a low differential pressure measurement under high-line (reference) conditions. Safe zero calibrations can be performed under high-line pressures.

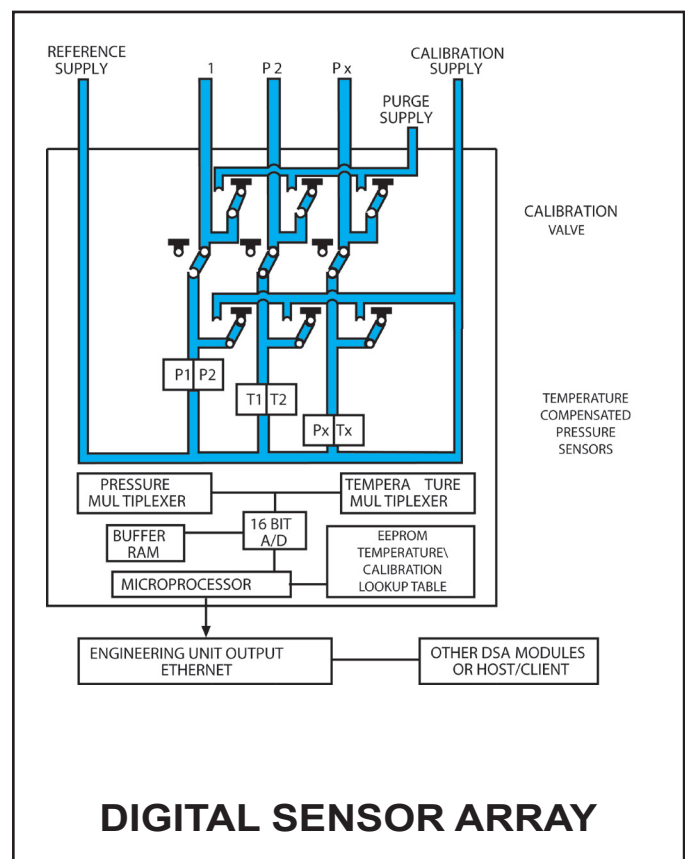

DSAENCL4000 Rack Mount Enclosure

Up to 8 DSA3016 Digital Sensor Array modules are designed to fit in Scanivalve's 19 inch rack mounted enclosures. Each enclosure incorporates a power supply, DSP processor, and multiple 16 bit A/D's to convert all analog pressures to Engineering Units. Communication interface is Ethernet TCP/IP or RS-232. Only 1 IP address is required for each rack mount enclosure (up to 128 pressures).

DSA4000 System Network

The DSAENCL4000 enclosure interfaces directly to a PC, host computer or Ethernet network via TCP/IP or RS-232. Scanivalve's optional Configuration Utility software for LabVIEW® Runtime is designed to assist a user in establishing communications and configuring the DSA enclosure.



DSAENCL4000

Additionally available is a Software Development Kit for users who want to write their own detailed data acquisition program in LabVIEW®. This Development Kit includes the Configuration Utility software and examples to assist a user in the setup of the system.

DSA3016 Specifications

Inputs (Px): Rear Access: 1/16 inch brass Swagelok® fittings (16 ea.)
Front Access: 1/8 inch brass Swagelok® fittings (16 ea.)

Full Scale Ranges: ±10 inch H₂O, 1, 2.5, 5, 15, 30, 50, 100, 250, 500, 600, 750 psid
(±2.5, 7, 17, 35, 100, 205, 345, 690, 1725, 3450, 4125, 5175 kPa)

Accuracy:
(Including linearity, hysteresis, and repeatability)

Sensor Pressure Range	Static Accuracy After Rezero (% F.S.)
10 inch H ₂ O 1 psid, 2.5 psid	±0.2 %
5 to 500 psid	±0.12%
501 to 750 psid	±0.05 %
	±0.08%

Resolution: 16 bit A/D

Scan Rate Maximum: 625 samples/channel/second (user configurable)

Operating Temperature: 0°C to 55°C standard

Overpressure Capacity: (with no damage)

10 inch H₂O = 2 psi (13.79 kPa)
1 psid = 5 psi (35kPa)
2.5 to 499 psid (3440 kPa) = 2.0x
500 psid (3450 kPa) = 1.5x
750 psid (5175 kPa) = 850psi (5860kPa)

Maximum Reference Pressure: 250 psig (1725 kPa)

Media Compatibility: Gases compatible with silicon, silicone, aluminum and BUNA-N

Weight: DSA3016/16Px: 4 lbs. 12 oz. (2.15 kgm)

DSAENCL4000 Enclosure Specifications

Communication

Protocol: TCP/IP or UDP

Connector Type: I/O: RJ-45
Trigger: Bendix PTO6A-12-10S, 10 pin female

Interface: Ethernet 10/100 BaseT (auto crossover feature)
RS-232 (9600 Baud)

Power Requirements: 115Vac @ .87 Amp (100 VA)
230Vac @ .44 Amp (100 VA)

Weight: DSAENCL4000: 19.5 lbs (8.85kg)
With 8 DSA3016 modules: 51.5 lbs (23.4kg)

LabVIEW® is a registered trademark of National Instruments.
Swagelok® is a registered trademark of Swagelok

Ordering Information

Module		19 Inch Enclosure
DSA3016 / 16Px - 500psid/xxpsid - RA		DSAENCL4000
Model	Pressure Ranges (Dual range shown) Px Inputs -RA Rear Access -FA Front Access	Model
	Inputs	
	- 16 Inputs/16 Sensors	
	- 8D 8 True Differential Sensors	
	-16D 16 True Differential Sensors (FA-Front Access 1/16" fittings only)	

Dimensions inches (cm)

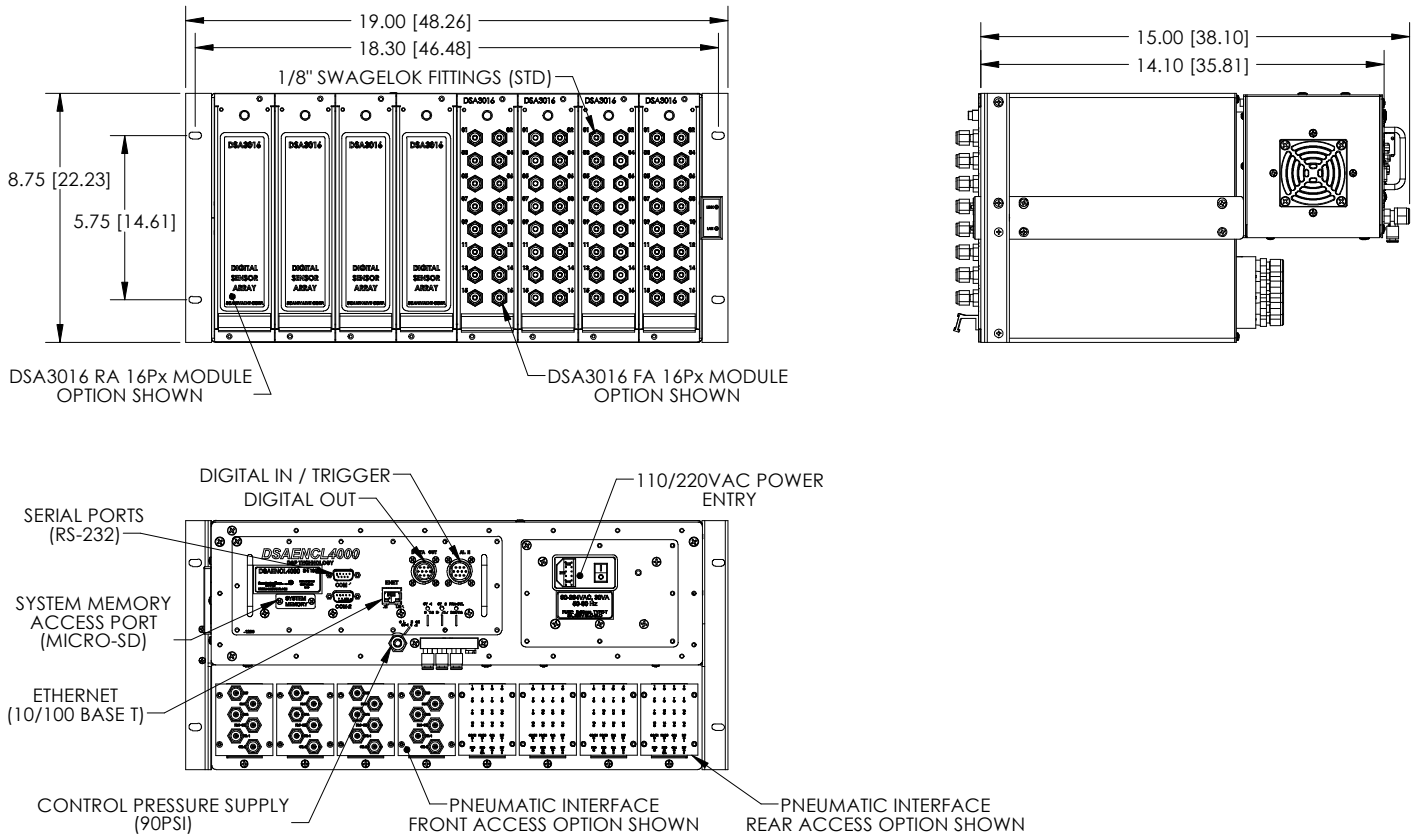

Scanivalve Headquarters
 1722 N. Madson Street
 Liberty Lake, WA 99019
 Tel: 509-891-9970
 800-935-5151
 Fax: 509-891-9481
 e-mail: scanco@scanivalve.com

Scanivalve
www.scanivalve.com